

 **ITALIANA**[®]
ferramenta

Trik

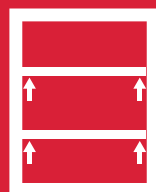

**SHELF
SUPPORTS**



SYMBOLS AND FINISHES LEGEND

SYMBOLS



= SHELF SAFELY LOCKED DURING TRANSPORTATION AND AT HOME



= ANTI-TURNOVER LOCKING SYSTEM



= NORMS / PATENTS



= PHILLIPS / POZIDRV



= WITH BUFFER



= PART NO.



= BLADE SLOT



= WITH MAGNET



= PCS. PER PACKAGE



= COMBI SLOT



= HEXAGONAL SOCKET



= NEWTON



= CAPACITY LOADING



= HEXALOBULAR SOCKET



= FRICTION



= WOOD / GLASS THICKNESS



= COUNTERSUNK HEAD



= AUTOMATIC



= HOLE DIAMETER



= PAN HEAD



= DROP DOWN



= DIAMETER



= FLANGE HEAD



= LENGTH



= FLAT HEAD



= STANDARD HINGE



= HEIGHT



= TRILOBULAR SCREW



= KIMANA HINGE



= RIGHT VERSION



= SELF-TAPPING SCREW



= FLAP HINGE



= LEFT VERSION



= EURO THREAD



= WITH SPRING



= SETTING CODE



= METRIC THREAD



= WITHOUT SPRING



= PCS. PER PAD



= PRE-INSERTED SCREW



= REVERSED SPRING



= CUT ON REQUEST



= PRE-INSERTED SCREW AND SPREADING BUSH



= SELF ADHESIVE



= WITH FLANGE

NOTE: Printing errors and omissions may exist despite our best efforts to ensure accuracy. We reserve the right to alter specifications without notice.

MATERIALS

ZA = Zinc Alloy

ST = Steel

HSS = High Speed Steel

BR = Brass

ABS = Acrylonitrile Butadiene Styrene

ZAnk = Nickel-plated Zinc Alloy

STzk = Zinc-plated Steel

AL = Aluminium

WD = Wood

EVA = Ethylene Vinyl Acetate

EP = ENGINEERING PLASTIC

+ **EP** = other engineering plastic available on request

SR = SOFT RUBBER

+ **SR** = other soft rubber available on request

EPn = Natural Engineering Plastic

EPc = Clear Engineering Plastic

SRn = Natural Soft Rubber

EPw = White Engineering Plastic

EPg = Grey Engineering Plastic

SRw = White Soft Rubber

EPwg = Water Green Engineering Plastic

SRb = Black Soft Rubber



FINISHES



= OTHER FINISHES AVAILABLE ON REQUEST

PART NO.	FINISHES	PART NO.	FINISHES	PART NO.	FINISHES
00	Insignificant finish	IF	Middle Grey	UT	T-Met 9007
AA	Natural	IJ	Light Grey	UZ	T-Met
AB	White	IL	Grey 20	WA	Bronzed
AE	White 9010	IN	Grey met. 26	WI	Burnished
EA	Black	JB	Bright Aluminium	XD	Satin-finished Steel
EC	Matt Black	JC	Aluminium - Chrome	YA	Nickel-plated
EE	Anthracite	JD	Matt Aluminium	YB	Bright Nickel-plated
EW	Grey 9007	JE	Satin-finished Aluminium	YC	Matt Nickel-plated
FU	Gunmetal	JF	Aluminium - Brass	YD	Satin-finished Nickel-plated
FV	Gunmetal V52	JG	Aluminium 5	YQ	Black Nickel
GR	Raw	JL	Aluminium PE 11	Z9	Black Zinc
HA	Brass-Plated	JM	Aluminium RAL 9006	ZA	Zinc alloy
HH	Tropicalized	KA	Chrome	ZN	Zinc-plated
HL	Raw Brass	KB	Bright Chrome	ZQ	Bright Gold
HX	Graphite	KC	Matt Chrome	ZY	Titanium
IA	Grey	NN	Metallic Beige	ZZ	Clear
IB	Metallic Grey	RO	Red		



TRIK



INSTALLATION AND ASSEMBLING ON FURNITURE MOUNTED AGAINST THE WALL
SHELF SUPPORTS INSERTION ON THE SHELF

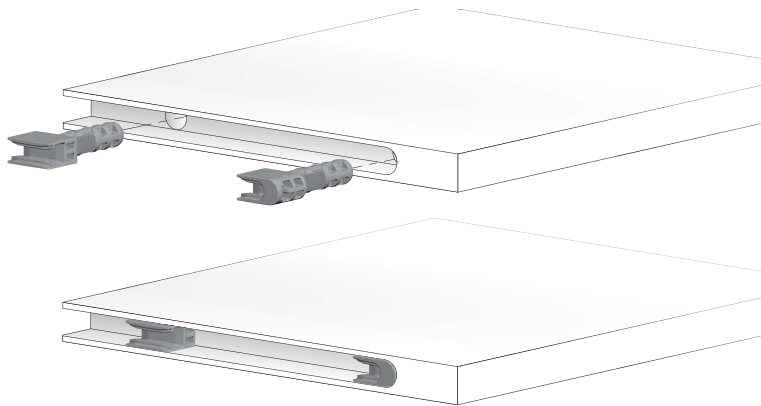

SHELF INSTALLATION

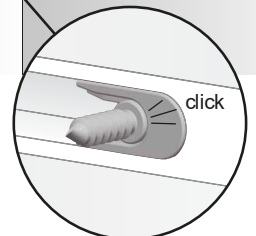
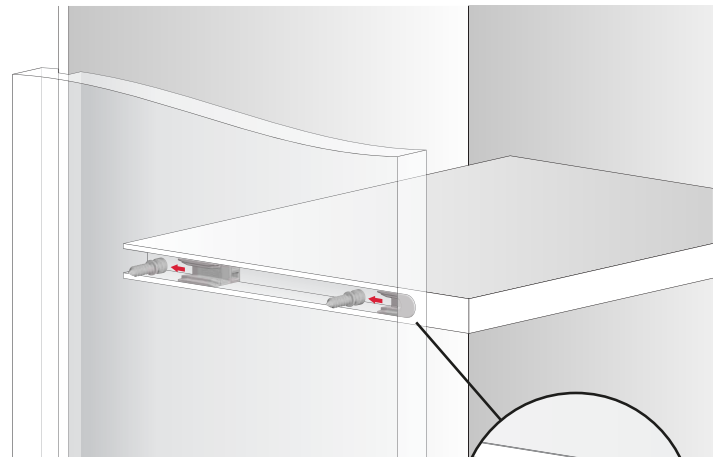

12 mm min.

DOWELS INSERTION ON THE SIDE PANEL

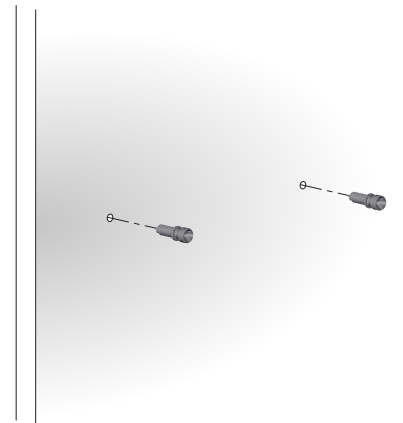



INSTALLATION AND ASSEMBLING ON BIFACIAL FURNITURE
SHELF SUPPORTS INSERTION ON THE SHELF

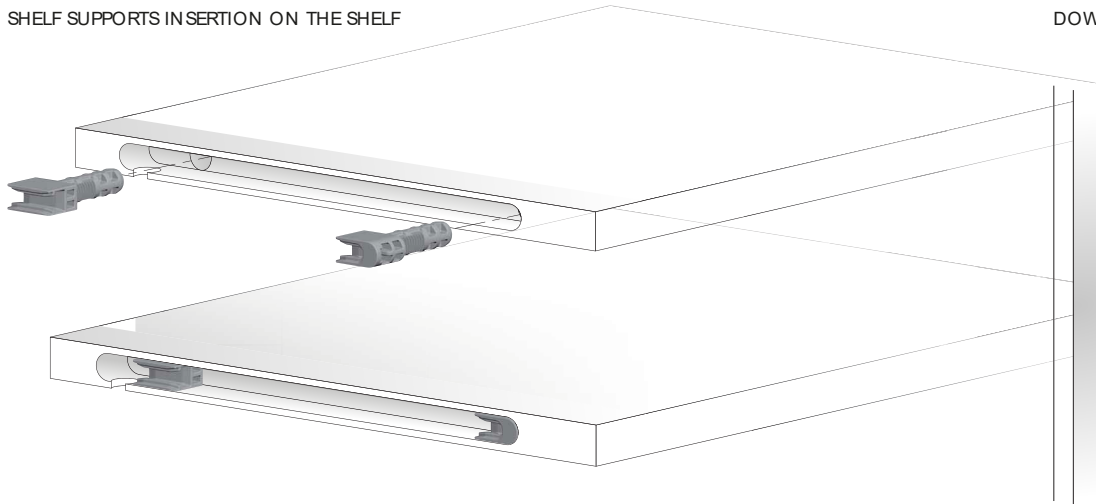

DOWELS INSERTION ON THE SIDE PANEL

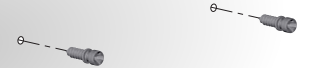

SHELF INSTALLATION

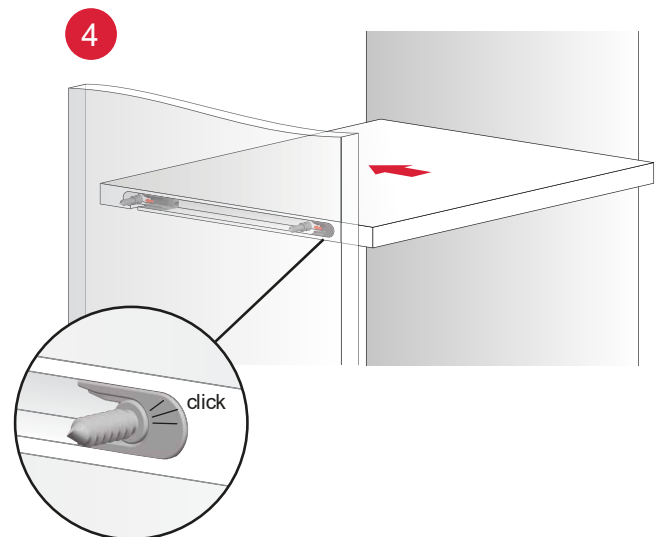
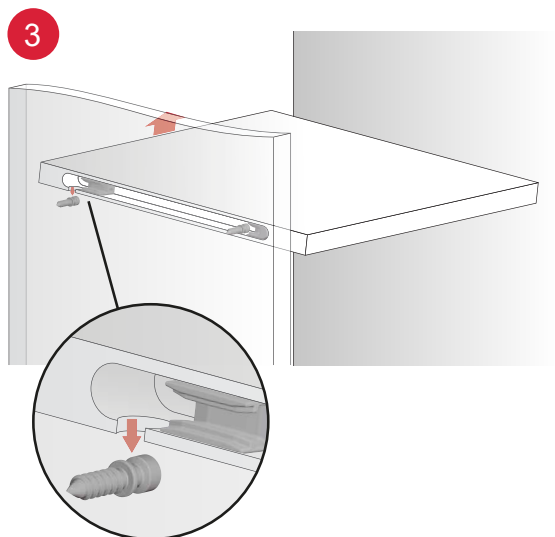
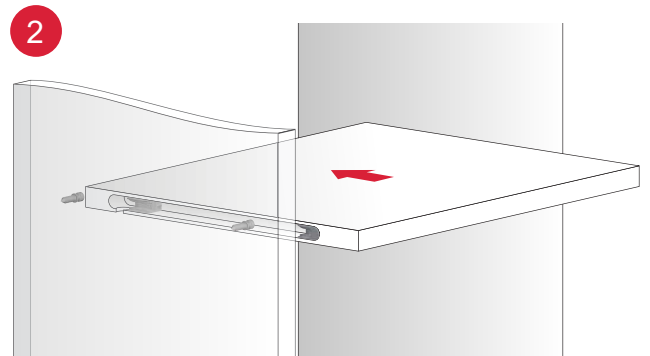
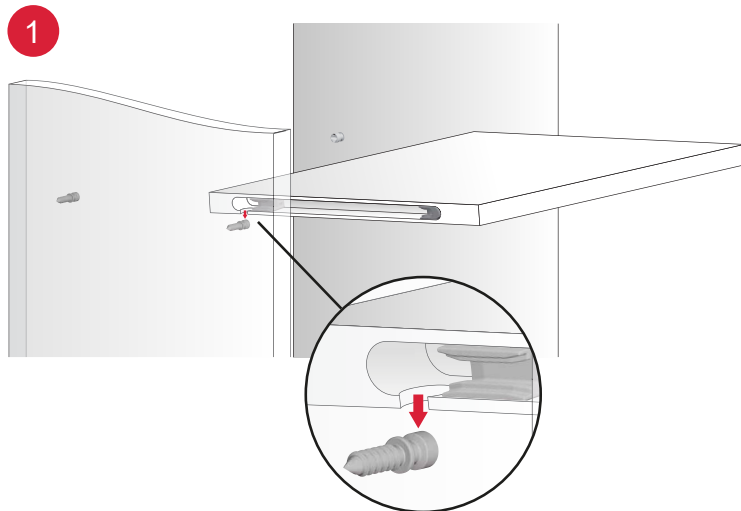



TRIK 8

STANDARD DRILLING PLAN

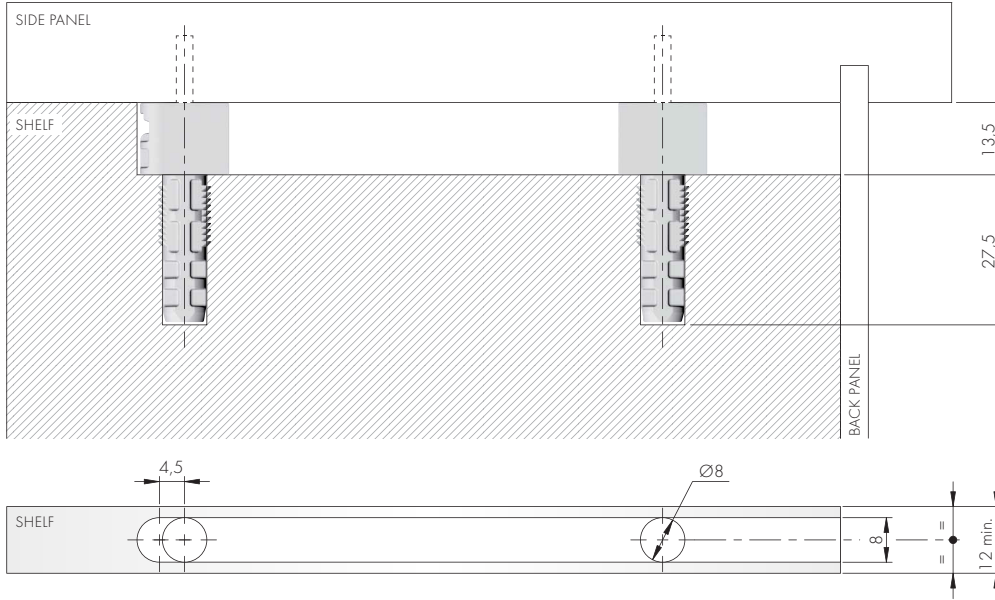

ALTERNATIVE DRILLING PLAN FOR THE APPLICATION ON BIFACIAL FURNITURE

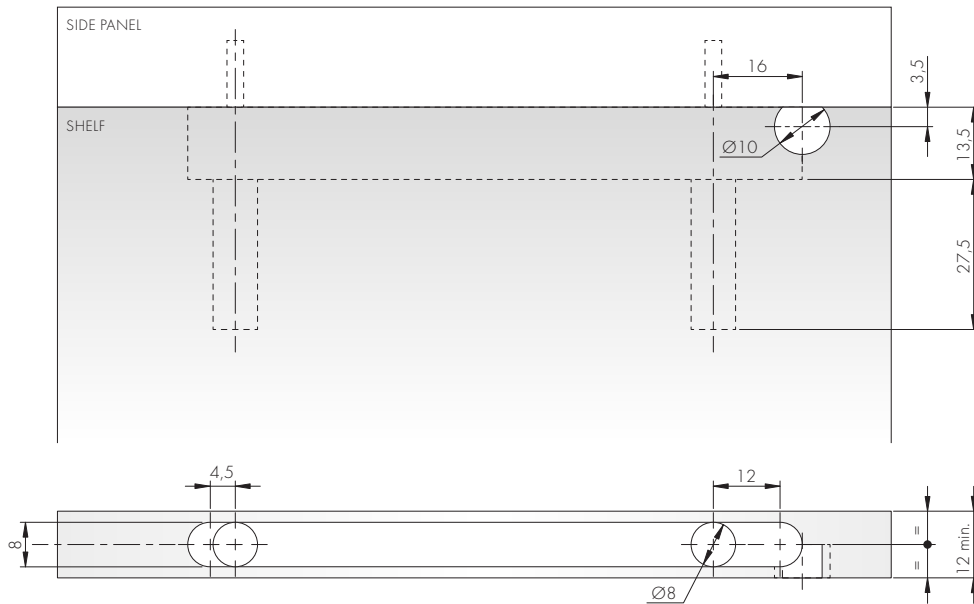

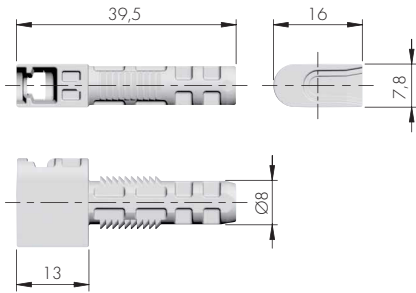

= Ø 8 mm

EP

= ... pcs.



12501010IJ

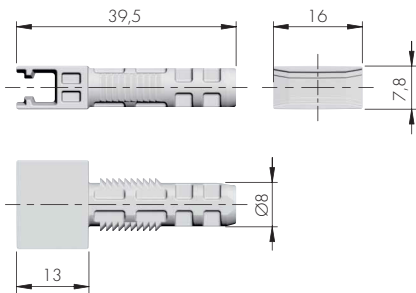

= Ø 8 mm

EP

= ... pcs.



12501020IJ

DOWEL FOR TRIK 8

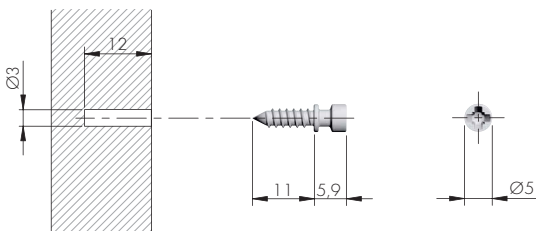

= Ø 3 mm



= PZ2

ST

= ... pcs.



12503010ZN