

2 x \varnothing 3,30 THRU
M4x0.7 THRU
✓ \varnothing 4,50 X 90°

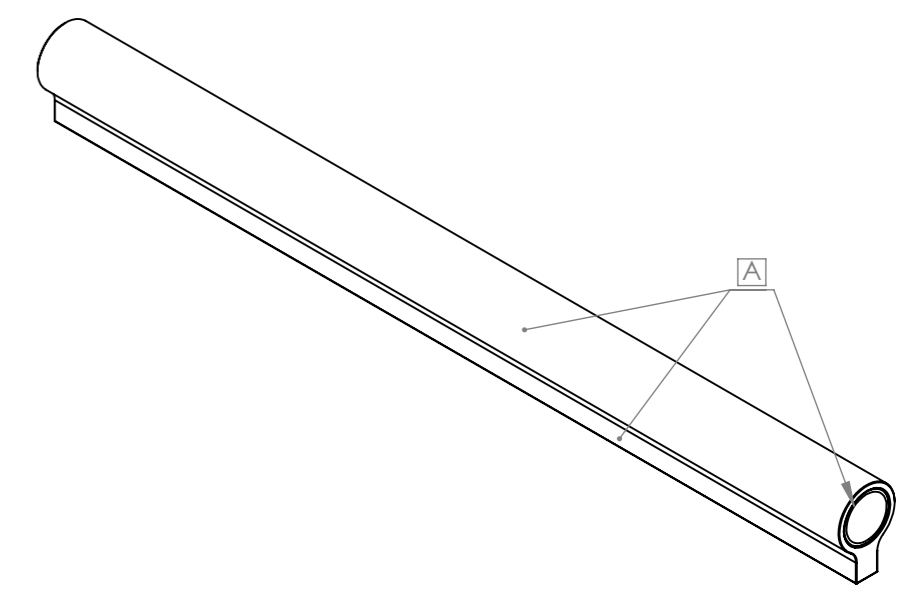
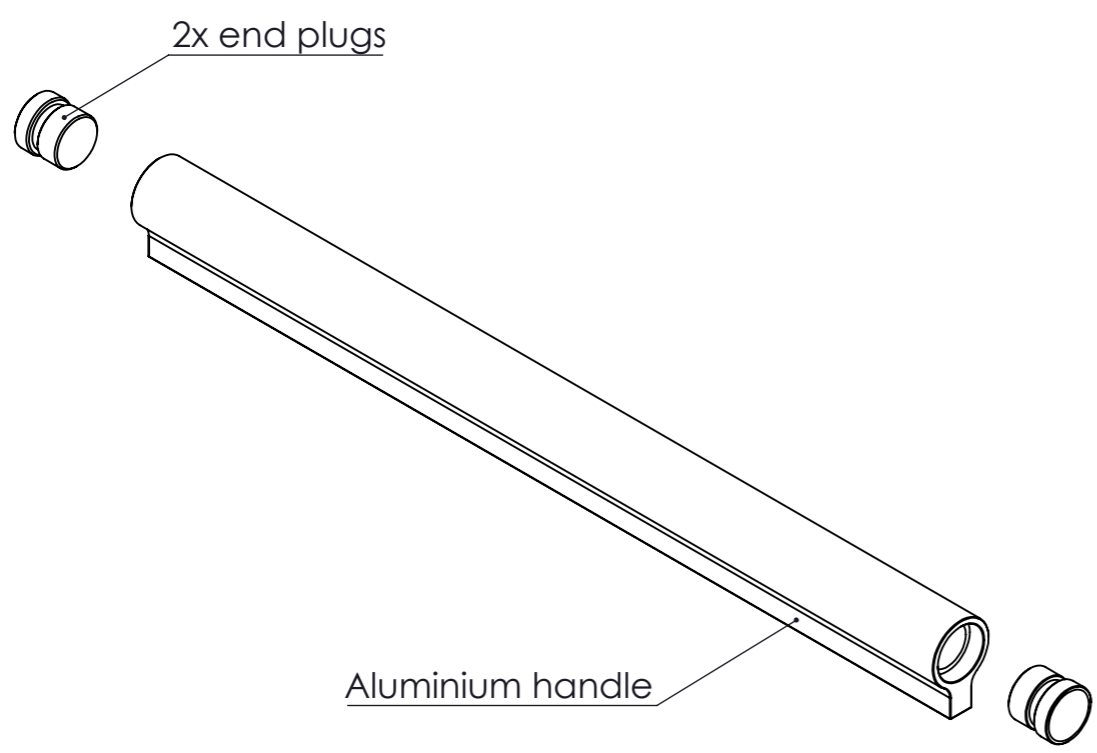

Part nr:	L	CC
460620064	100	64
460620224	300	224

Rev.:	Date:	Name:	Description:

Part name: LUCENTE	Projection: 	Sheet format: A3	Tolerance unless otherwise specified DS/ISO 2768-1M <table border="1"> <tr> <td>Linear dimensions:</td> <td>0-3</td> <td>3-6</td> <td>6-30</td> <td>30-120</td> <td>120-400</td> <td>400-1000</td> <td>1000-2000</td> </tr> <tr> <td></td> <td>±0,1</td> <td>±0,1</td> <td>±0,2</td> <td>±0,3</td> <td>±0,5</td> <td>±0,8</td> <td>±1,2</td> </tr> <tr> <td>Angle:</td> <td colspan="2">±0,5°</td> <td colspan="4">Radius: ±5%</td> <td></td> </tr> </table>	Linear dimensions:	0-3	3-6	6-30	30-120	120-400	400-1000	1000-2000		±0,1	±0,1	±0,2	±0,3	±0,5	±0,8	±1,2	Angle:	±0,5°		Radius: ±5%				
	Linear dimensions:	0-3		3-6	6-30	30-120	120-400	400-1000	1000-2000																		
	±0,1	±0,1	±0,2	±0,3	±0,5	±0,8	±1,2																				
Angle:	±0,5°		Radius: ±5%																								
Designer: Bartoli design	Sheet: 1 of 3	Scale: 1:2	<p>Requirements confer PS-001 Technical Specifications</p>																								
Item no.: 460620XXX	Drawn by: NLS 18-07-24	Weight:																									
Material: Aluminium	Finish requirements (PS-004) [A] = Most important surface [B] = Important surface [C] = Less important surface																										
COPYRIGHT: THIS DRAWING MAY NOT BE COPIED OR REPRODUCED IN ANY WAY WITHOUT DIRECT PERMISSION FROM FURNIPART A/S																											

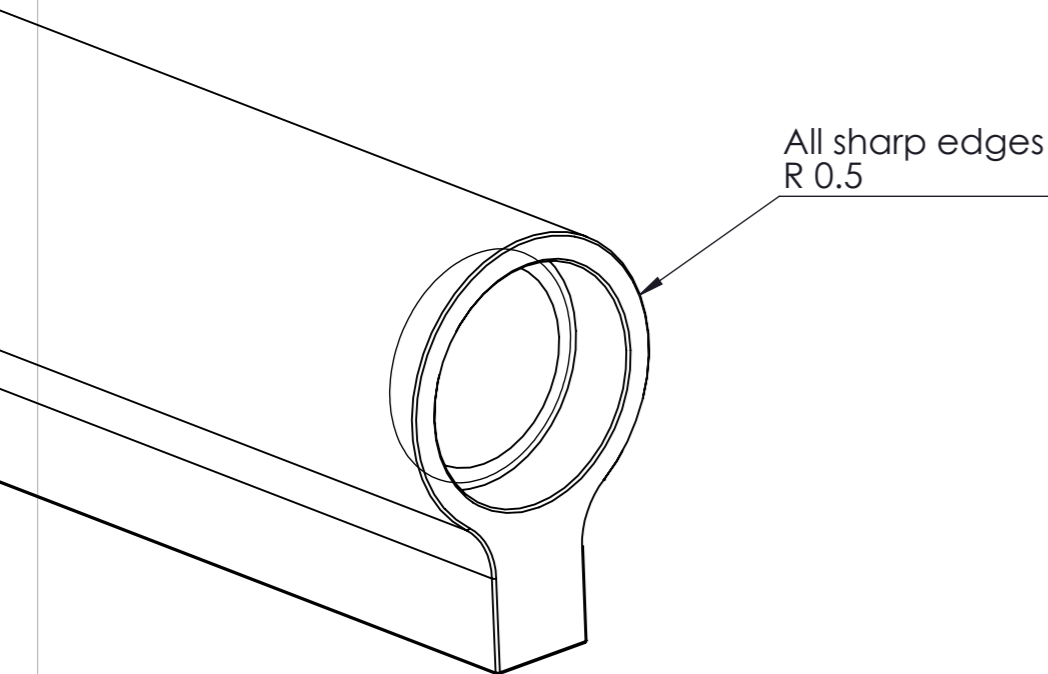
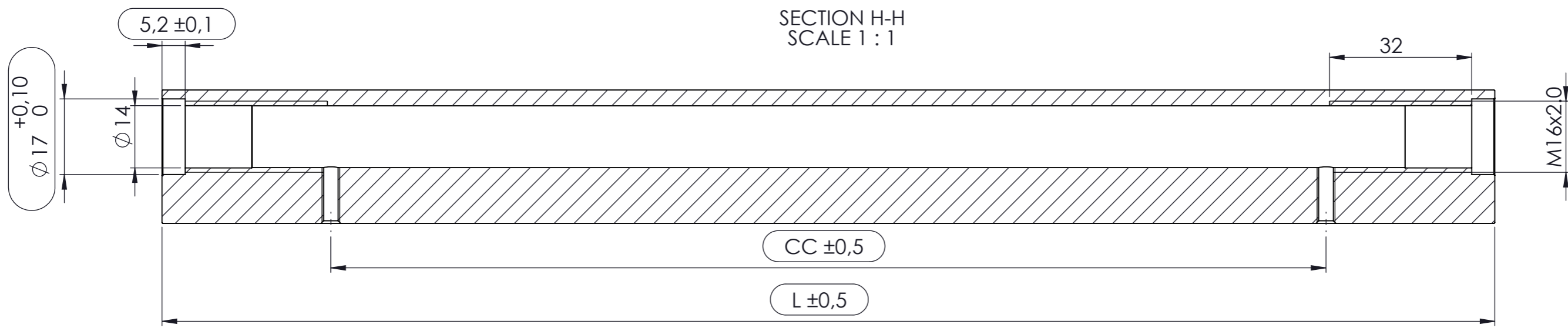

Part nr:	L	CC
460620064	100	64
460620224	300	224

Rev.:	Date:	Name:	Description:

Part name: LUCENTE	Projection: 	Sheet format: A3	Tolerance unless otherwise specified DS/ISO 2768-1M <table border="1" style="font-size: small; width: 100%;"> <tr> <td>Linear dimensions:</td> <td>0-3</td> <td>3-6</td> <td>6-30</td> <td>30-120</td> <td>120-400</td> <td>400-1000</td> <td>1000-2000</td> </tr> <tr> <td></td> <td>±0,1</td> <td>±0,1</td> <td>±0,2</td> <td>±0,3</td> <td>±0,5</td> <td>±0,8</td> <td>±1,2</td> </tr> <tr> <td>Angle:</td> <td colspan="2">±0,5°</td> <td colspan="2">Radius:</td> <td colspan="3">±5%</td> </tr> </table>	Linear dimensions:	0-3	3-6	6-30	30-120	120-400	400-1000	1000-2000		±0,1	±0,1	±0,2	±0,3	±0,5	±0,8	±1,2	Angle:	±0,5°		Radius:		±5%		
	Linear dimensions:	0-3		3-6	6-30	30-120	120-400	400-1000	1000-2000																		
	±0,1	±0,1	±0,2	±0,3	±0,5	±0,8	±1,2																				
Angle:	±0,5°		Radius:		±5%																						
Sheet: 2 of 3	Scale: 1:2	Weight:																									
Designer: Bartoli design	Drawn by: NLS 18-07-24																										
Item no.:	Finish requirements (PS-004) [A] = Most important surface [B] = Important surface [C] = Less important surface																										
Material: Aluminium	Requirements confer PS-001 Technical Specifications																										
COPYRIGHT: THIS DRAWING MAY NOT BE COPIED OR REPRODUCED IN ANY WAY WITHOUT DIRECT PERMISSION FROM FURNIPART A/S																											

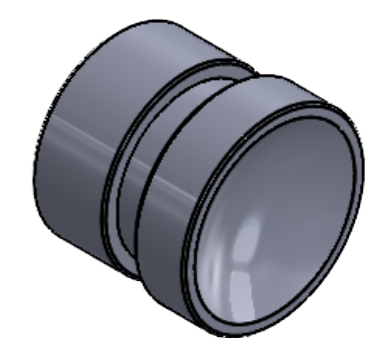
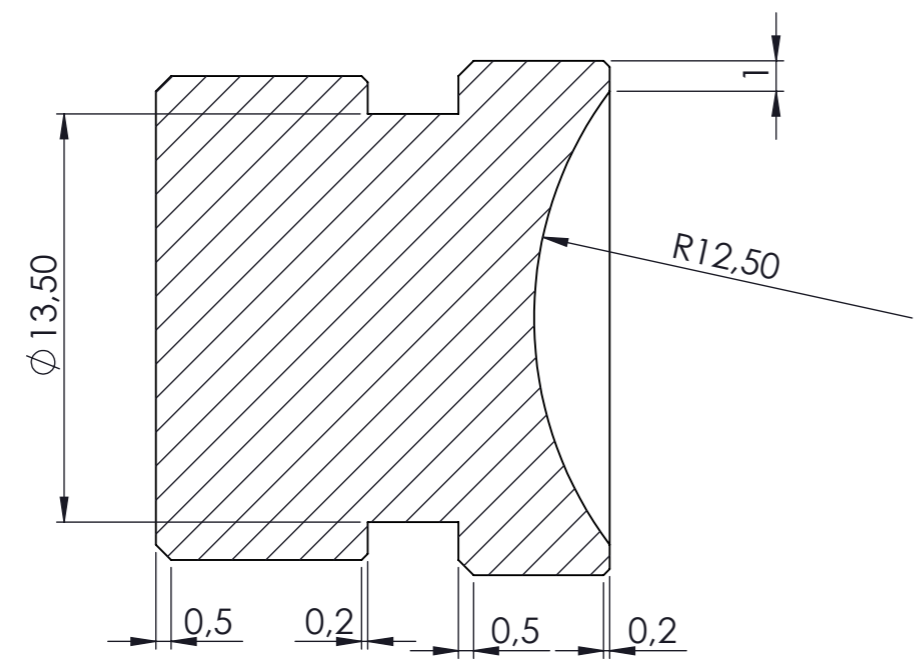
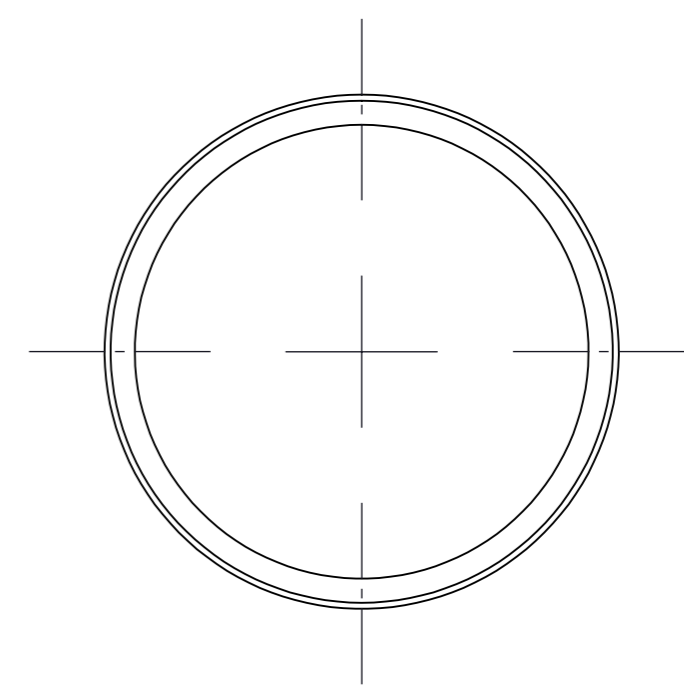
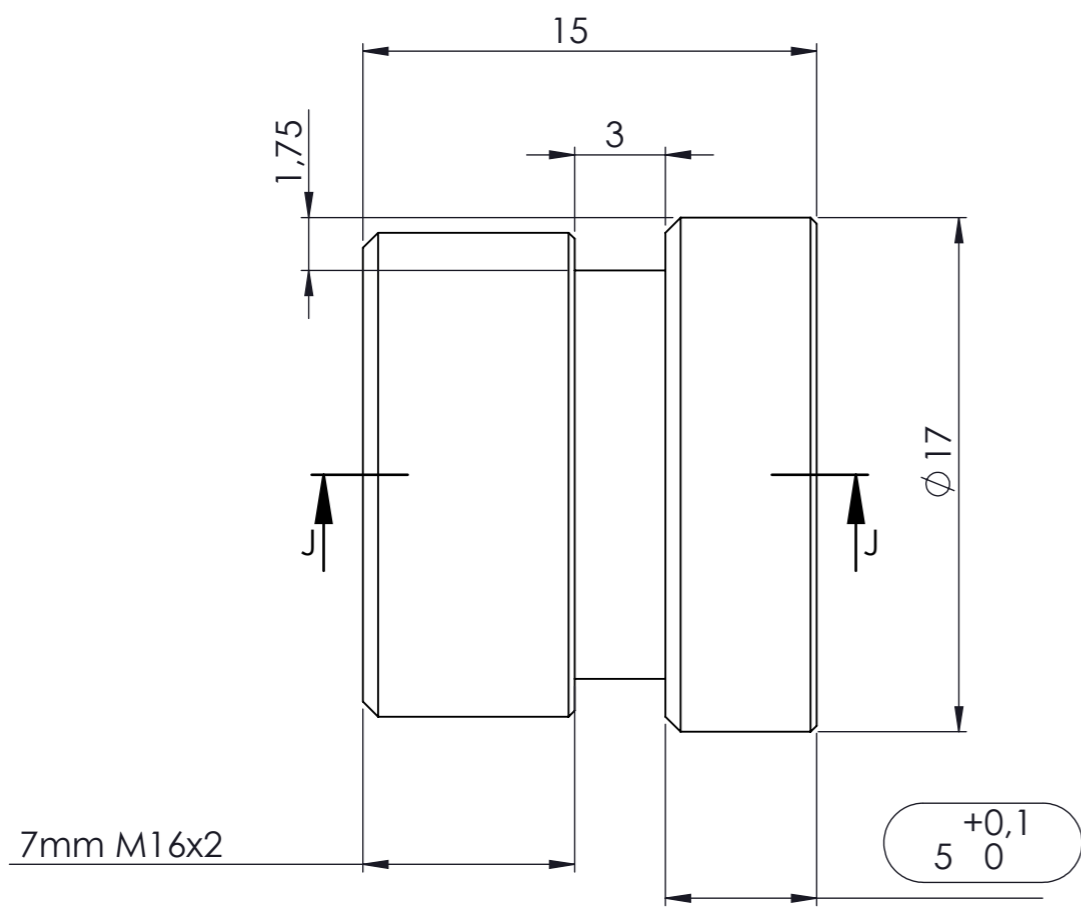

Part nr:	L	CC
460620064	100	64
460620224	300	224

Rev.:	Date:	Name:	Description:

Part name: LUCENTE	Projection: 	Sheet format: A3	Tolerance unless otherwise specified DS/ISO 2768-1M Linear dimensions: <table border="1"><tr><td>0-3</td><td>3-6</td><td>6-30</td><td>30-120</td><td>120-400</td><td>400-1000</td><td>1000-2000</td></tr><tr><td>±0,1</td><td>±0,1</td><td>±0,2</td><td>±0,3</td><td>±0,5</td><td>±0,8</td><td>±1,2</td></tr></table> Angle: ±0,5° Radius: ±5%	0-3	3-6	6-30	30-120	120-400	400-1000	1000-2000	±0,1	±0,1	±0,2	±0,3	±0,5	±0,8	±1,2
	0-3	3-6		6-30	30-120	120-400	400-1000	1000-2000									
±0,1	±0,1	±0,2	±0,3	±0,5	±0,8	±1,2											
Sheet: 3 of 3	Scale: 2:1	Weight:															
Designer: Bartoli design	Drawn by: NLS 18-07-24	Finish requirements (PS-004) [A] = Most important surface [B] = Important surface [C] = Less important surface	furnipart [®] Requirements confer PS-001 Technical Specifications														
Item no.:	Material: Aluminium																
COPYRIGHT: THIS DRAWING MAY NOT BE COPIED OR REPRODUCED IN ANY WAY WITHOUT DIRECT PERMISSION FROM FURNIPART A/S																	