

Bisagra de 110°

Webcode
DQDELA

Planificación

Dimensiones de la bisagra y cálculo de los juegos con ajuste en fábrica (distancia de la base = 0 mm)

Puerta por interior en plena apertura

Recubrimiento angular (Total)

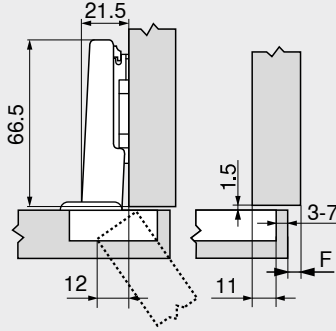
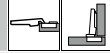

F Juego

Tope central (Medio)

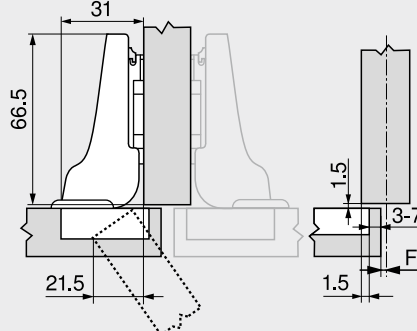
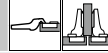

Montaje interior (Insertada)

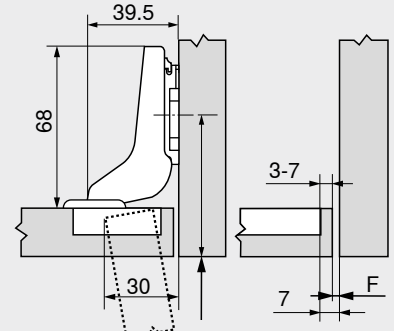
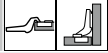

Retroceder la posición de atornillado de la base en función del espesor del frente FD +1.5 mm

Distancia de cazoleta TB

MD	Recubrimiento del frente FA (mm)															
	5	6	7	8	9	10	11	12	13	14	15	16	17	18		
0												3	4	5	6	7
3							3	4	5	6	7					
6				3	4	5	6	7								
9	3	4	5	6	7											
MD	Distancia de base (mm)															

MD	Recubrimiento del frente FA (mm)																
	-4.5	-3.5	-2.5	-1.5	-0.5	0.5	1.5	2.5	3.5	4.5	5.5	6.5	7.5	8.5			
0													3	4	5	6	7
3													3	4	5	6	7
6													3	4	5	6	7
9													3	4	5	6	7
MD	Distancia de base (mm)																

MD	Recubrimiento del frente FA (mm)											
	-7	-6	-5	-4	-3	-2	-1	0				
0								3	4	5	6	7
3								3	4	5	6	7
6								3	4	5	6	7
9								3	4	5	6	7
MD	Distancia de base (mm)											

Juego mínimo del juego F para frentes con radio del frente (R = 1 mm) con ajuste en fábrica

Distancia de cazoleta TB (mm)	Espesor del frente FD (mm)											
	16	18	19	20	21	22	23	24	25	26	28	30
3	0.5	0.8	1.0	1.2	1.5	1.8	2.2	2.7	3.5	4.3	Δ	Δ
4	0.5	0.8	1.0	1.2	1.4	1.7	2.0	2.5	3.1	3.8	Δ	Δ
5	0.5	0.8	0.9	1.2	1.4	1.7	2.0	2.4	2.9	3.4	Δ	Δ
6	0.5	0.8	0.9	1.2	1.3	1.6	1.9	2.3	2.7	3.2	Δ	Δ
7	0.5	0.8	0.9	1.1	1.3	1.6	1.9	2.2	2.6	3.0	Δ	Δ
Adicional para un ajuste lateral de +2 mm												
	+0.2	+0.4	+0.4	+0.5	+0.5	+0.5	+0.5	+0.5	+0.5	+0.5	+0.5	+0.5

Δ Recomendamos un ensayo de montaje

Ajuste

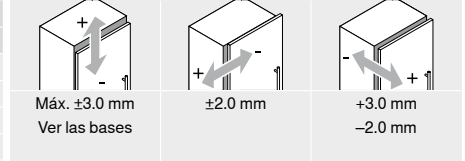

Montaje por atornillado

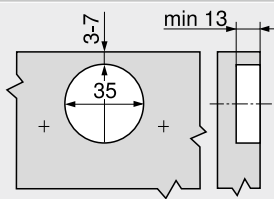

Montaje INSERTA | por encaje a presión

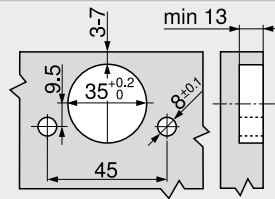

Cotas de la cazoleta

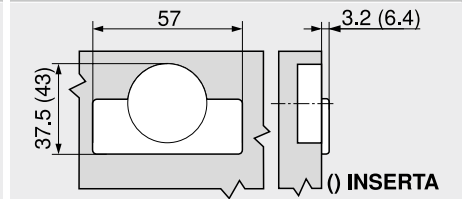

() INSERTA