

**Perfil de aluminio STUDY para
puerta angosta de cristal con
capacidad de 20 kg**

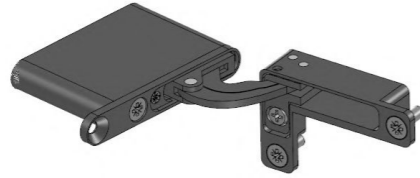

Bisagra STUDY



Ángulo de apertura

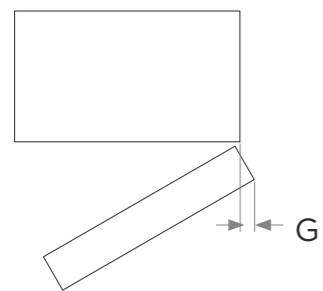
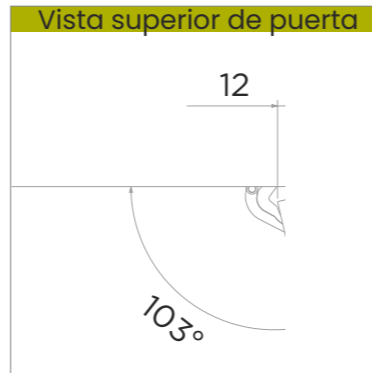

G = espacio de rotación

	ESPESOR DE PUERTA (mm)							
	18	20	22	24	26	28	30	32
D3	0.0	0.2	0.5	0.9	1.4	2.1	3.1	4.7
D4	0.0	0.2	0.5	0.9	1.4	2.0	2.9	4.2
D5	0.0	0.2	0.5	0.8	1.3	2.0	2.8	3.9
D6	0.0	0.2	0.5	0.8	1.3	1.9	2.7	3.7

El espacio necesario puede reducirse en función del radio de los bordes de la puerta.

Aplicación de bisagras

$$Y = (X - W) \quad W = (X - Y) \quad X = (W + Y)$$

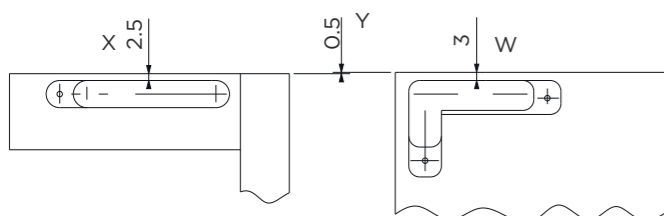
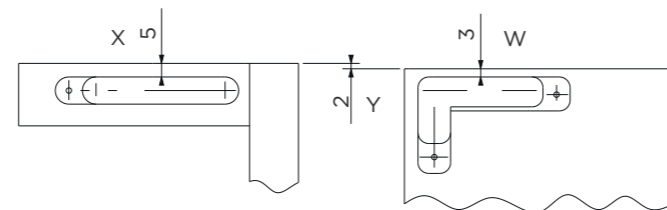
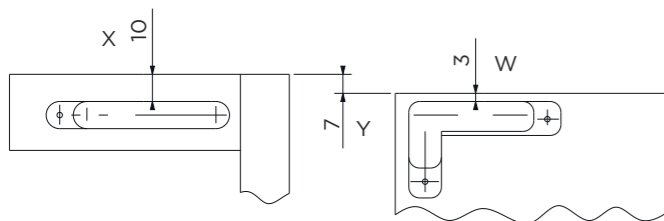

AJUSTES

AJUSTE FRONTAL
+ 2mm / - 0.5mm

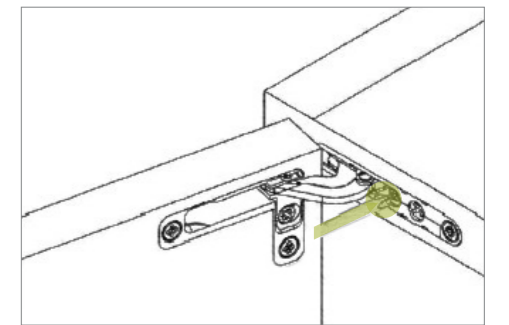
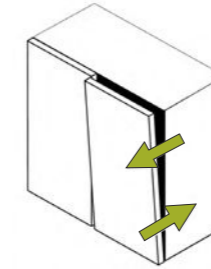

AJUSTE LATERAL
+ 2mm / - 2mm

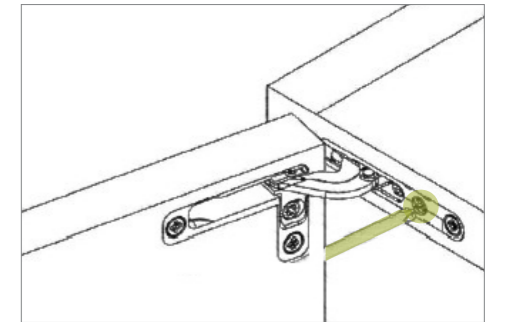
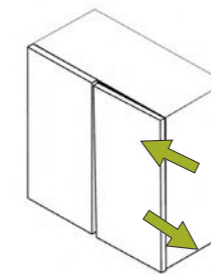

AJUSTE VERTICAL
+ 1.5mm / - 1.5mm

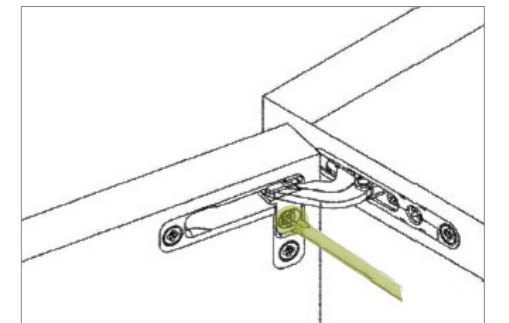
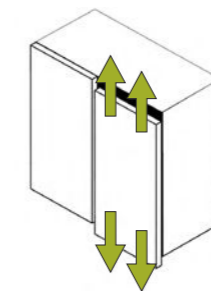

PROCESO DE FRESADO PARA SU INSTALACIÓN

$$A = (17 + D) - S$$

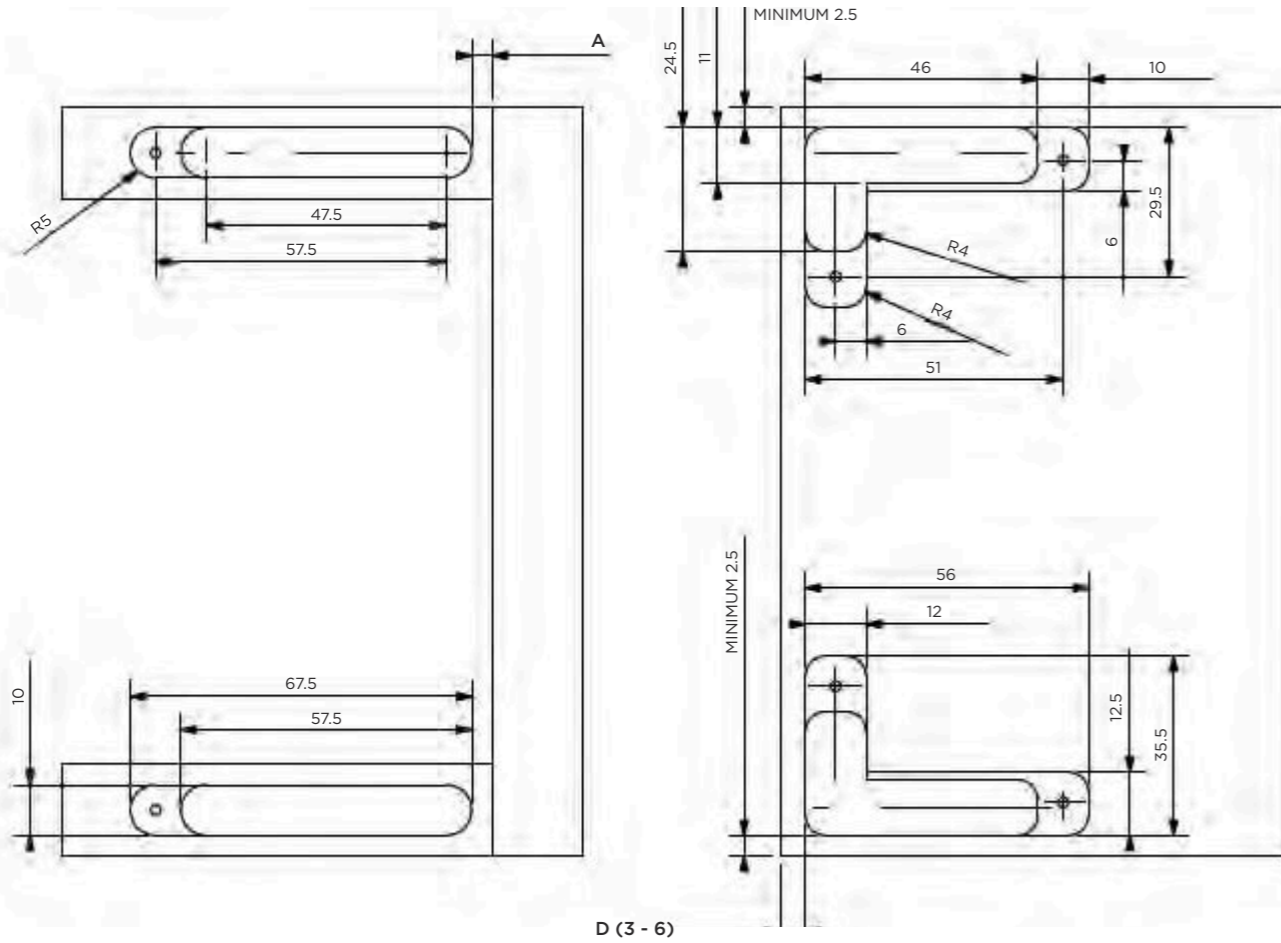

D (3 - 6)

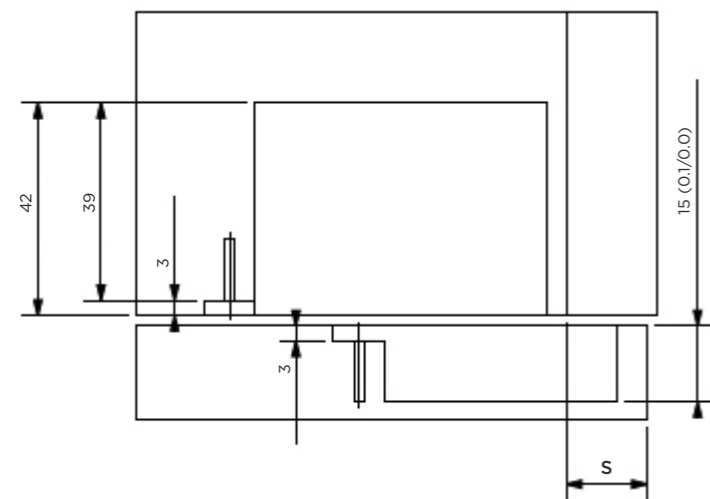

TECHNICAL SPECIFICATIONS:

AVAILABLE WITH SOFT CLOSING
INTEGRATED, PUSH TO OPEN,
OR WITHOUT SPRING
DOOR WEIGHT MAX: 20KG
DOOR WIDTH MAX: 600MM
DOOR HEIGHT MAX: 2000MM
OPENING ANGLE: 105°
MINIMUM THICKNESS OF PANELS: 18MM

BISAGRAS STUDY 20KG

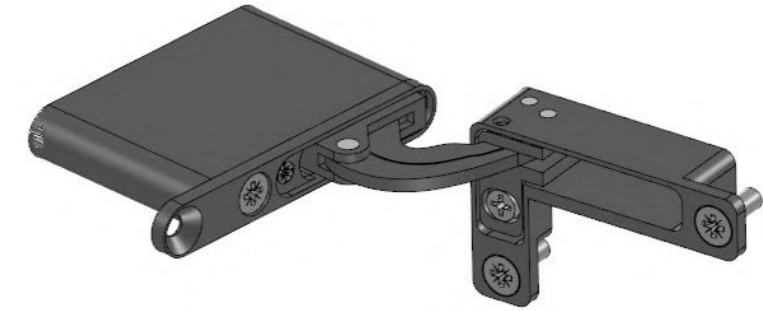

Bisagras STUDY para capacidad de carga de 20 kg

328.703

'suave de lado derecho

328.704

'suave de lado izquierdo

■ **PERFIL DE ALUMINIO STUDY**

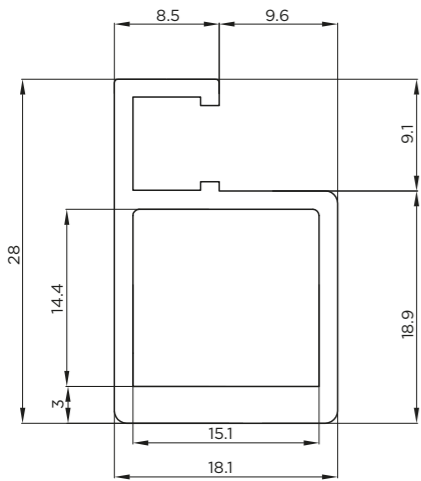
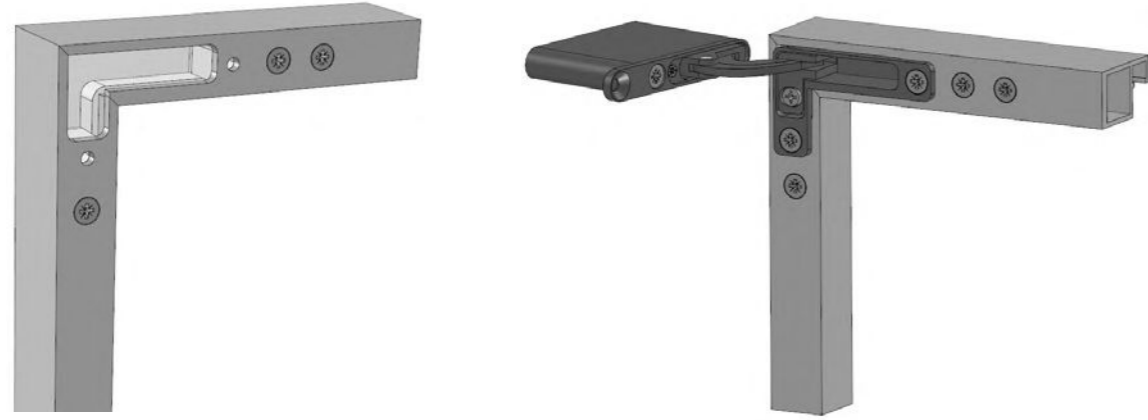

328.700 Perfil de aluminio Study para corte, acabado Brown Metal Grey

SELLO PERIMETRAL

328.707 Sello perimetral para cristal

JALADERA DE PERFIL STUDY

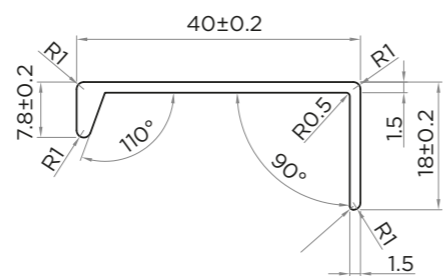
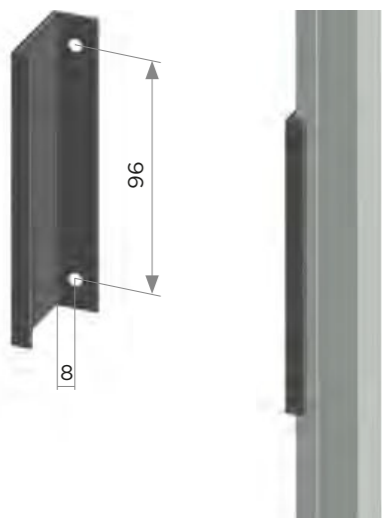

■ **BRAKETS PARA EL ARMADO DE PUERTA**

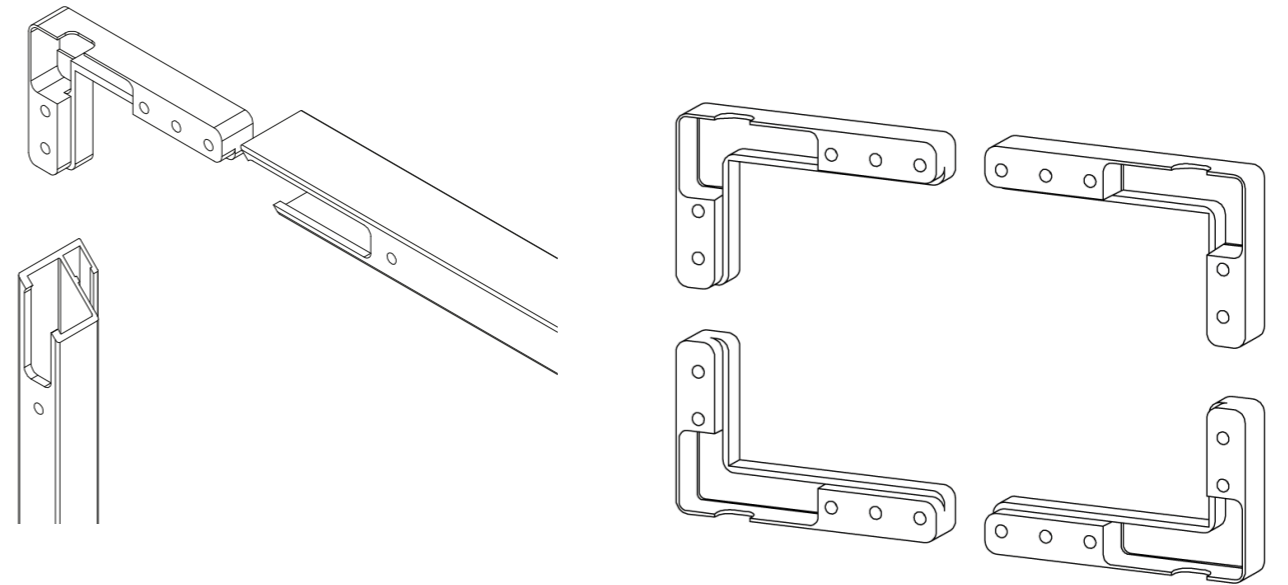

328.716 Set de ángulos de fijación 2 derechas y 2 izquierdas + tornillería M4x12

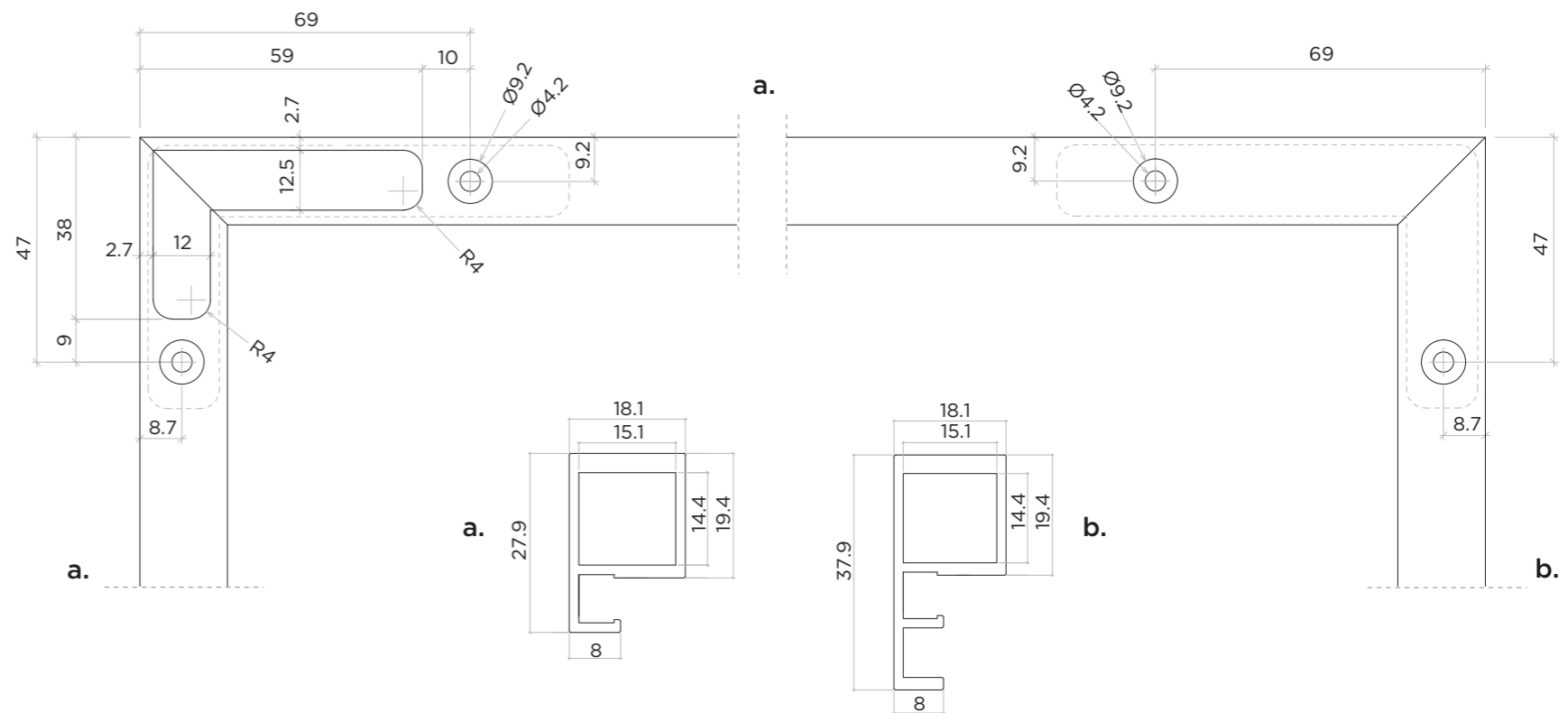

■ **PERFIL DE ALUMINIO STUDY**

328.708 Perfil de aluminio STUDY con jaladera para corte, acabado Brown Metal Grey

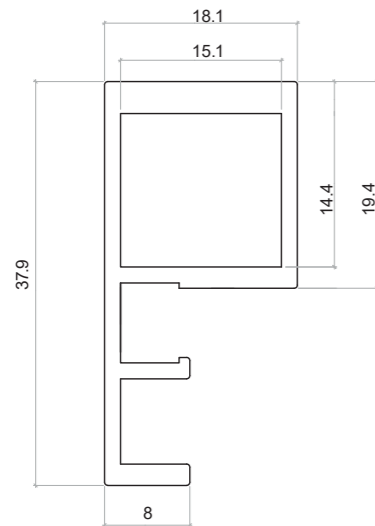

PERFIL DE ALUMINIO STUDY

328.709 Soporte para atornillar bisagras STUDY

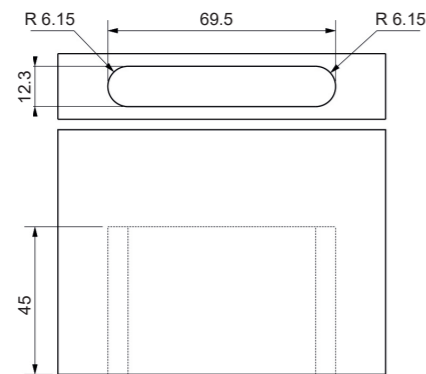

■ **SOPORTE PARA ATORNILLAR BISAGRAS STUYDY**

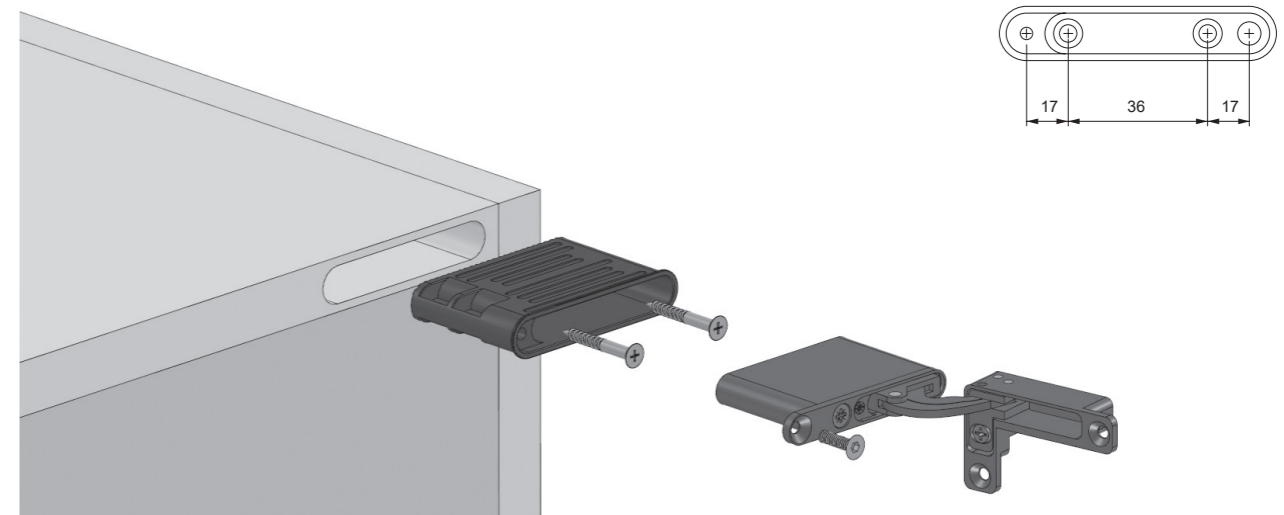

MAQUINADO PARA SOPORTE PARA ATORNILLAR BISAGRAS STUDY

$$A = (16 + D) - S \quad Y = (X - W)$$

$$W = (X - Y)$$

$$X = (W + Y)$$

