

DOOR INSTALLATION

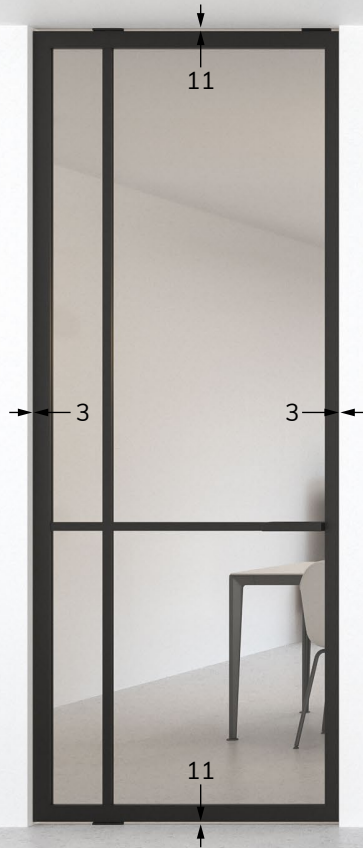

STANDARD JOINT DIMENSIONS

PORTAPIVOT 5730



PORTAPIVOT 5730
+ DOOR JAMBS



PORTAPIVOT 4245

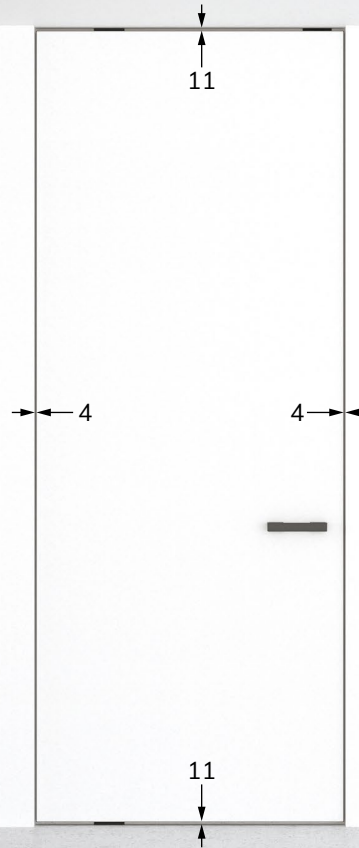

PORTAPIVOT 4245
+ DOOR JAMBS

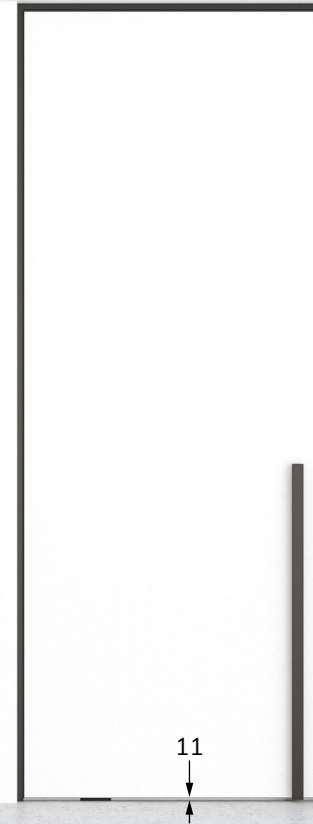

PORTAPIVOT GLASS

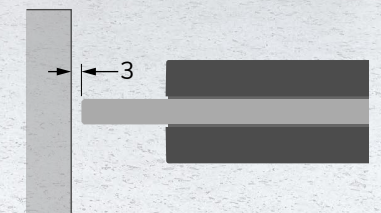
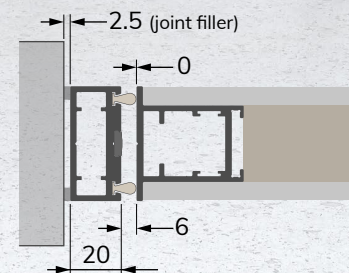
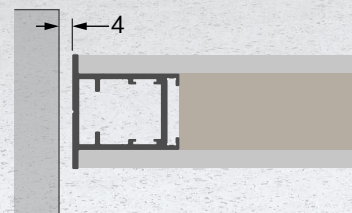
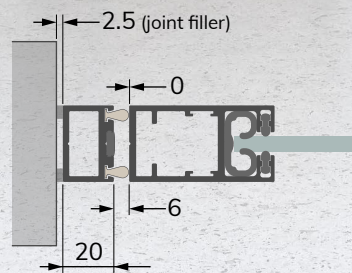
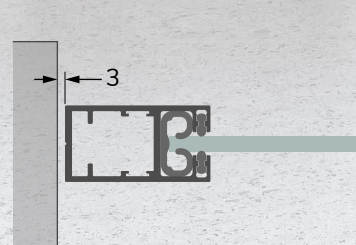
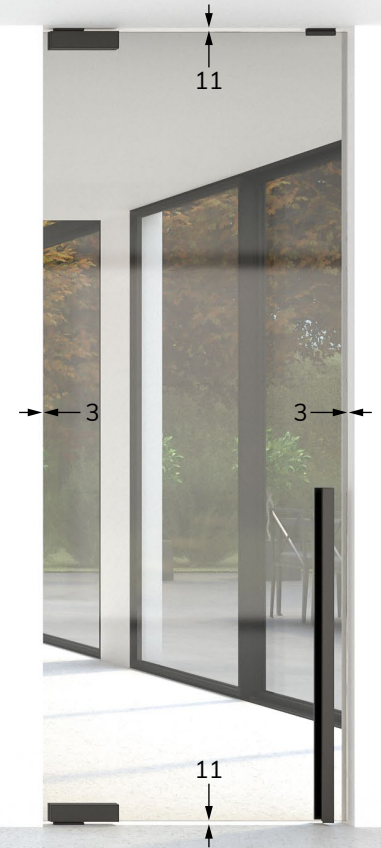

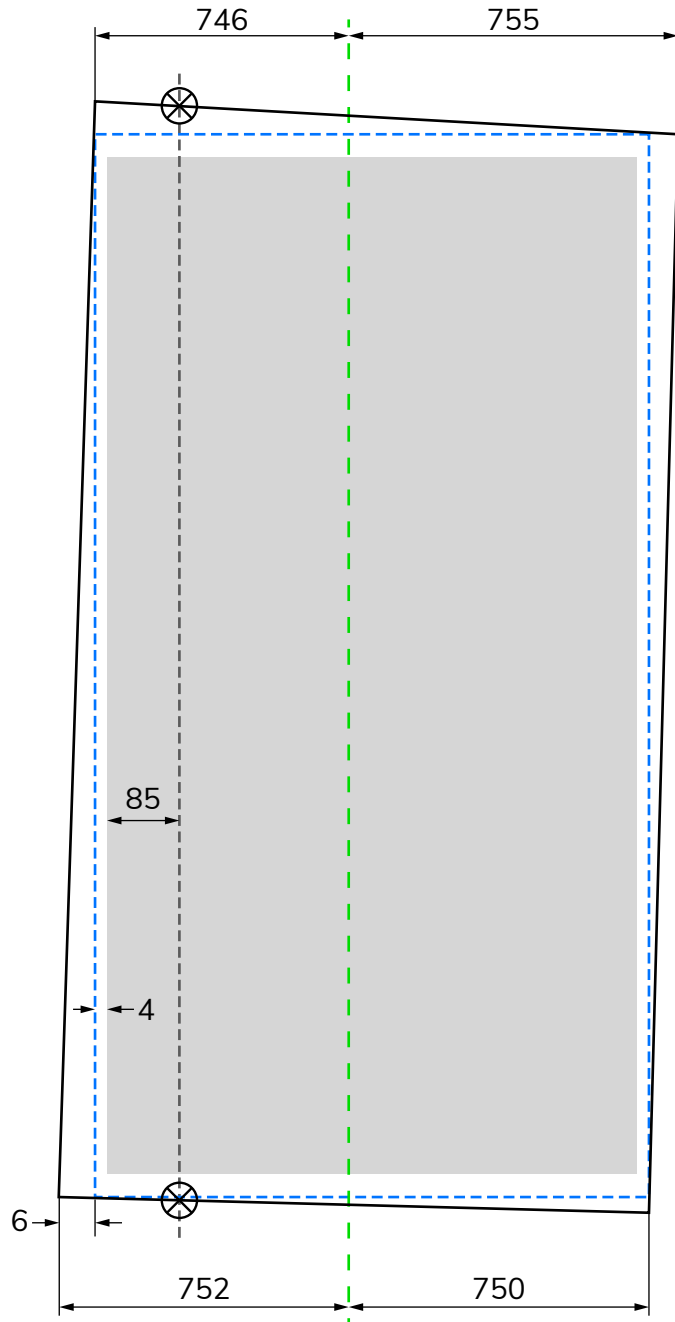

DEFINE PIVOT AXIS

In this example, the pivot axis is placed at 85 mm from the door leaf edge.

The bottom left side of the doorway is 6 mm wider than the top left: $752 - 746 = 6$ mm

Depending on the door thickness, you also need to consider the minimum joint: see table below.

To mark the pivot axis point on the floor for this example, add the 4 mm joint and 6 mm slanting to the 85 mm pivot axis location:

$$85 + 6 + 4 = 95 \text{ mm}$$

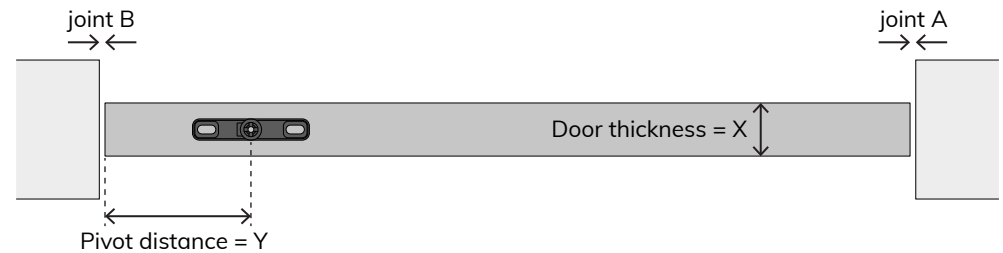

Y ▼	A = B					
1500	2	2	2	2	2	2
1000	2	2	2	2	3	3
500	2	2	2	3	3	3
250	2	3	3	3	4	4
85	3	3	4	5	7	9
X ▶	<30	30	40	50	60	70

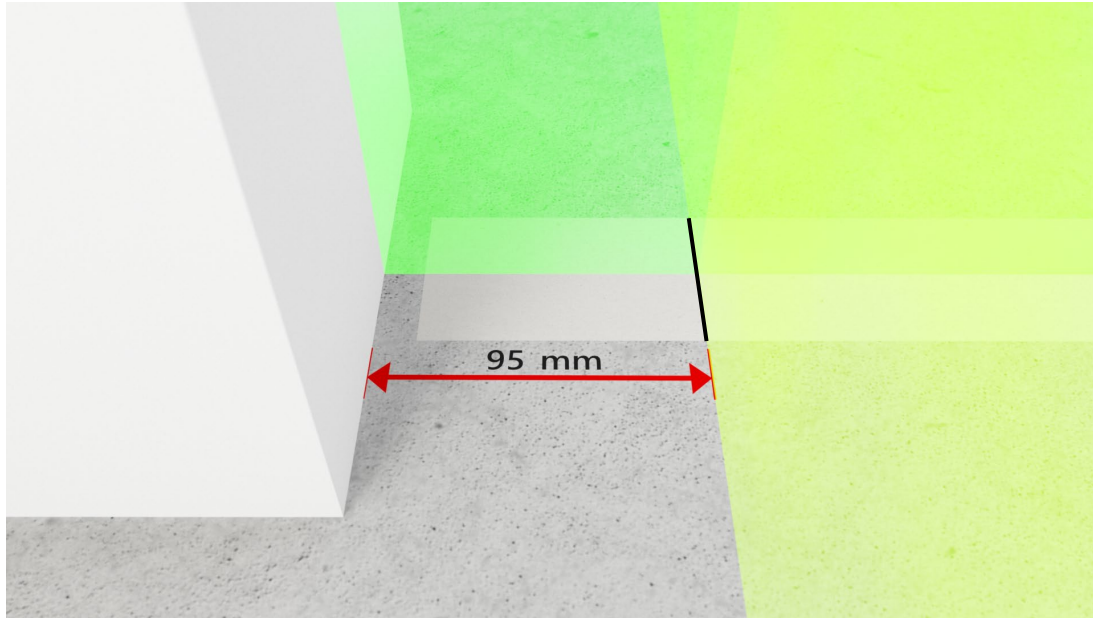

MARK PIVOT AXIS

Apply masking tape on the floor.

Measure and mark the pivot axis location onto the masking tape.

Place the laser in the doorway, exactly on top of the pivot axis marking.

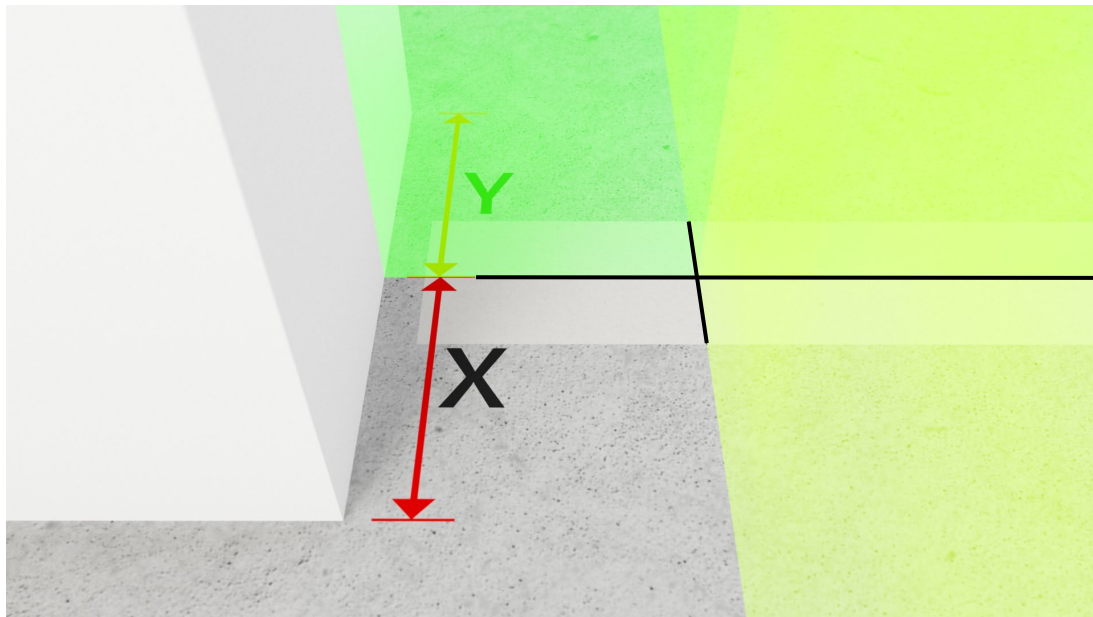

Position the second laser plane exactly on the desired door leaf center location.
(In this example: $X=Y$)

Mark the door leaf centerline onto the masking tape.

DRILL PIVOT MOUNT HOLES

Align the drill tool exactly on top of the center lines and mark the 2 drilling holes.

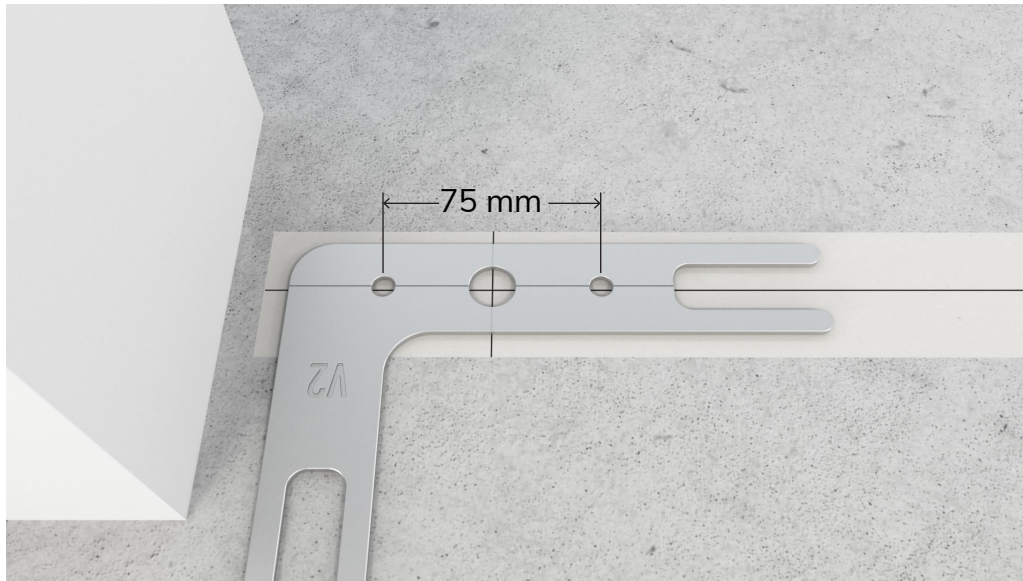

Depending on subsurface, different plugs may be required.



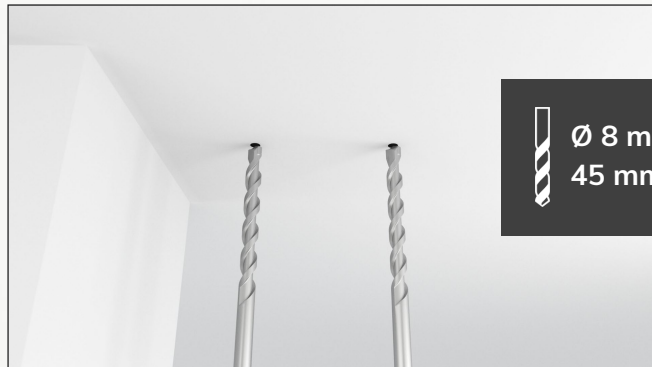
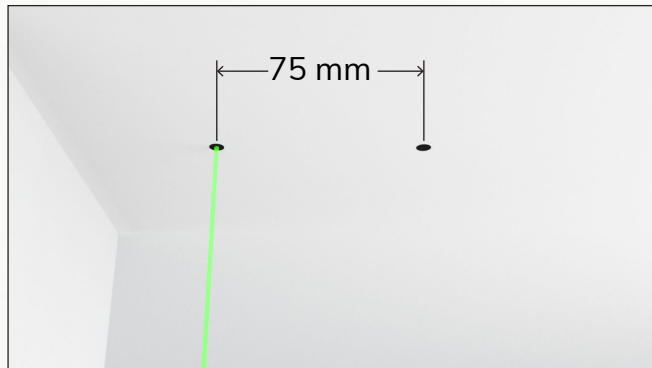

Use a laser to project and mark both holes to the ceiling. Drill holes and insert Fischer plugs.

SYNCHRONIZE PIVOT AXIS HEIGHT IN DOORWAY

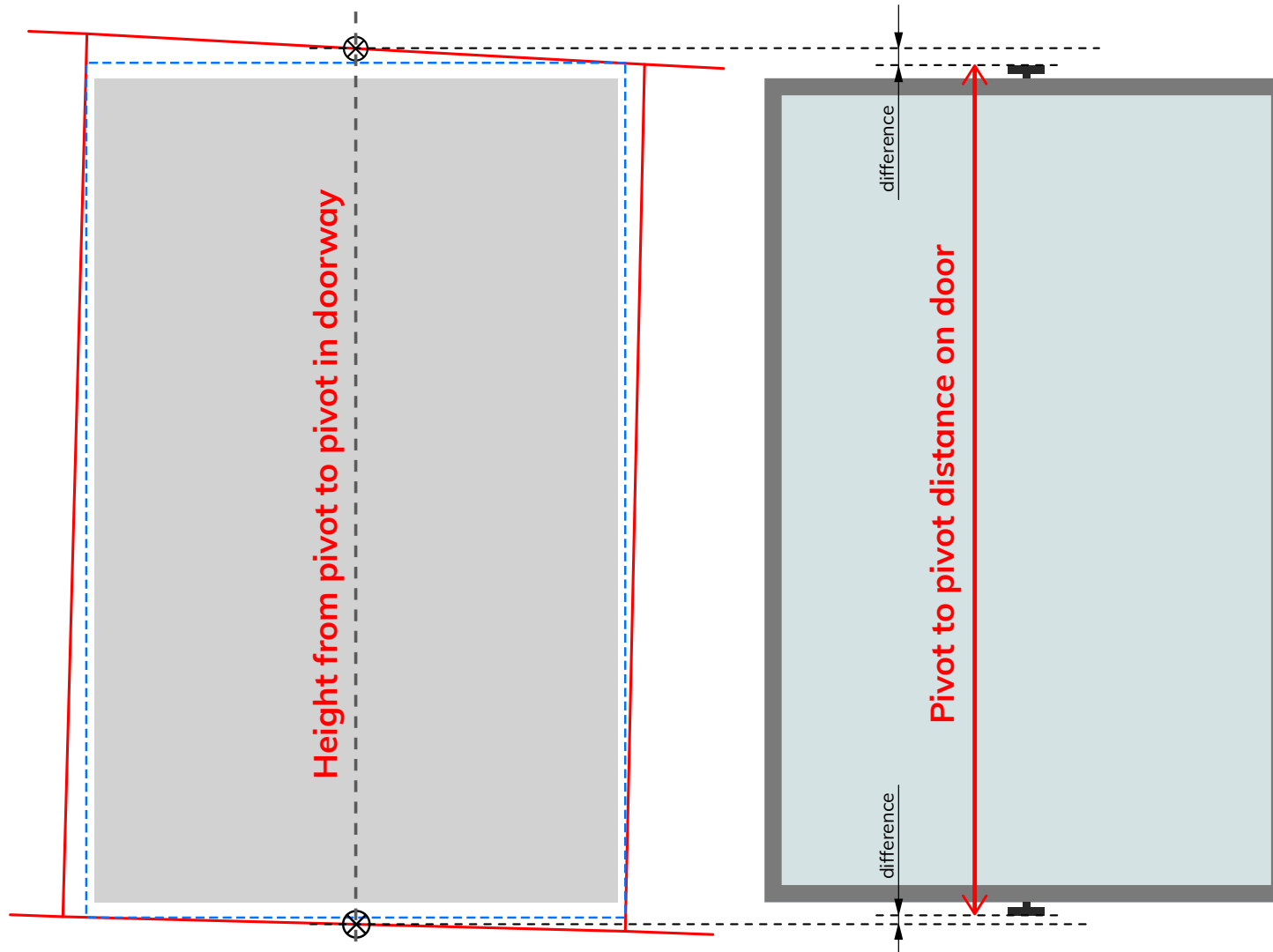

Compare the pivot to pivot distance of the door with the measured doorway height at the axis point.

Synchronize them if necessary, using a method described on the next page.

ADJUST HINGE HEIGHT / JOINT DIMENSIONS

To increase the joint dimensions, there are 3 methods:

METHOD 1



1. Use supplied shims between hinge and door leaf. This is the preferred method for the bottom hinge.

METHOD 2



2. Use supplied shims between hinge and floor/ceiling (= less stable).

METHOD 3



3. Adjust the inbus screws to move the hinge further away from the door leaf (loosen 4 hinge screws first). (only possible for non compressable door structure)

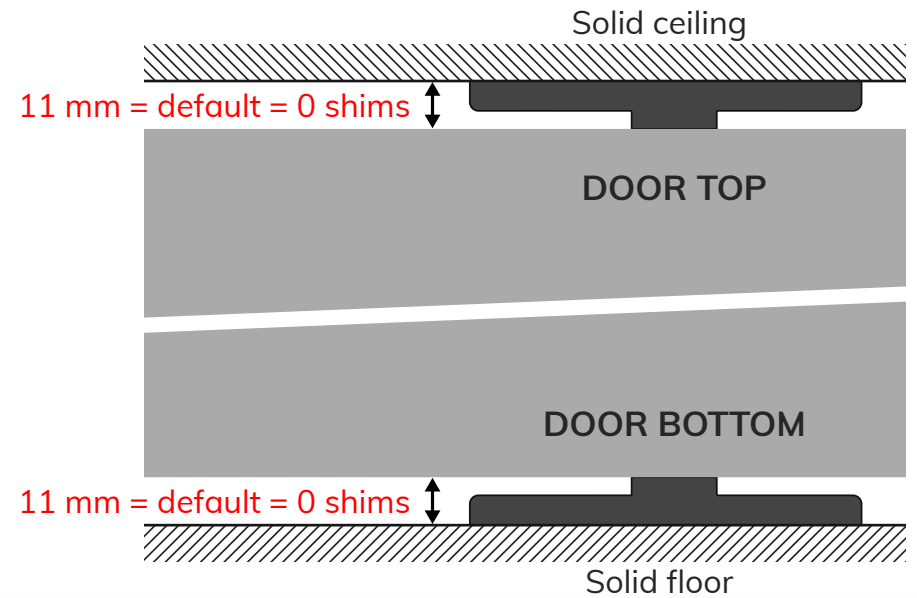

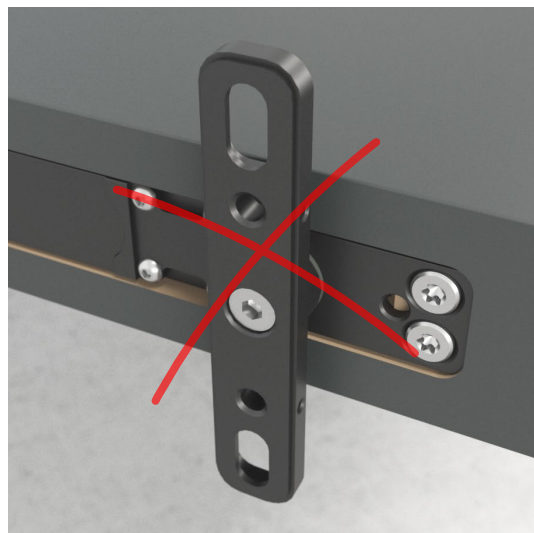

DOOR LEAF INSTALLATION

Make sure both pivots are in their 'closed' position.

Be careful when manipulating the self closing pivot. This will snap into position with large force!

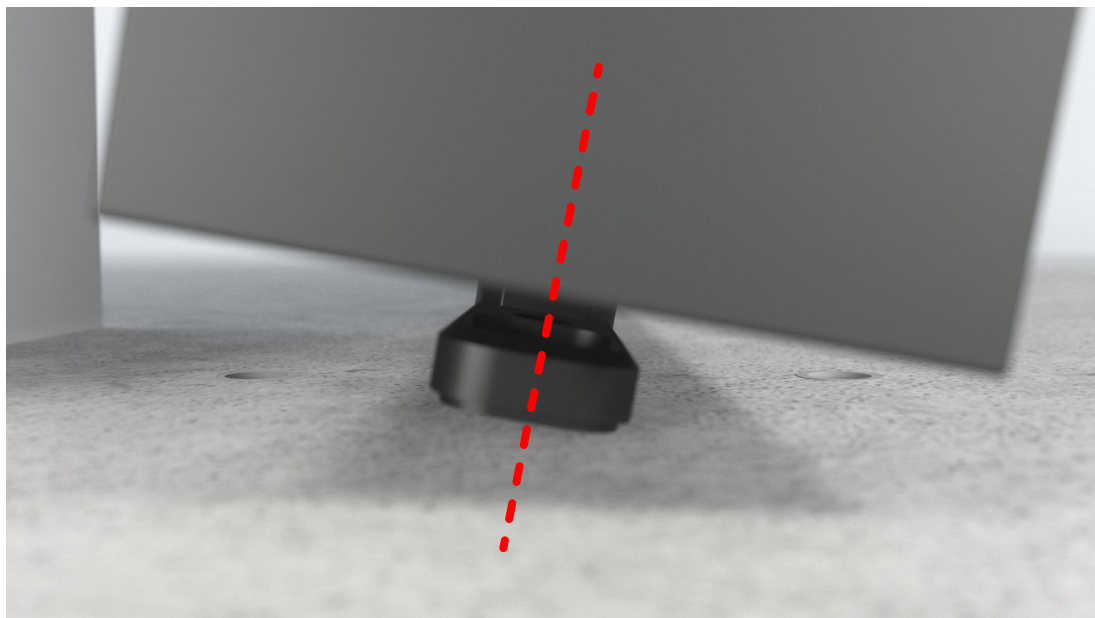

Place the door leaf in the doorway, and position the bottom pivot in between the 2 mounting holes at the axis position.



Tilt the door leaf upright, and keep it in place.

StealthPivot NL and StealthPivot XL share identical installation steps

Use the drill tool to rotate the pivot mount in place.
Repeat for the bottom pivot mount.

Always rotate the pivot mount in the closing direction of the door! If not, the door will be blocked in its opened position.

Be careful for paintwork

Install the octagonal inserts at 'position 1' in the top mount, then insert screws but do not fully tighten yet. **Repeat for the bottom pivot mount.**

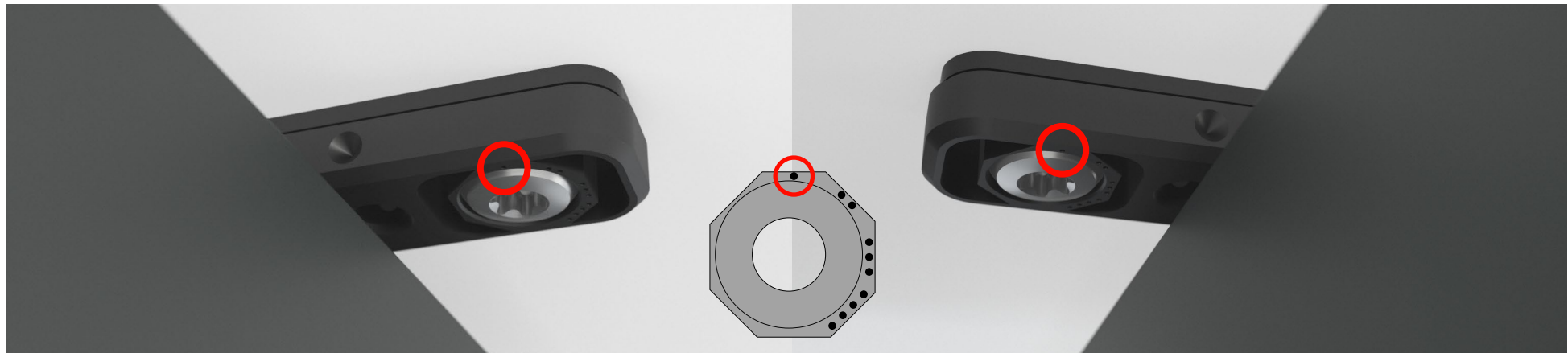

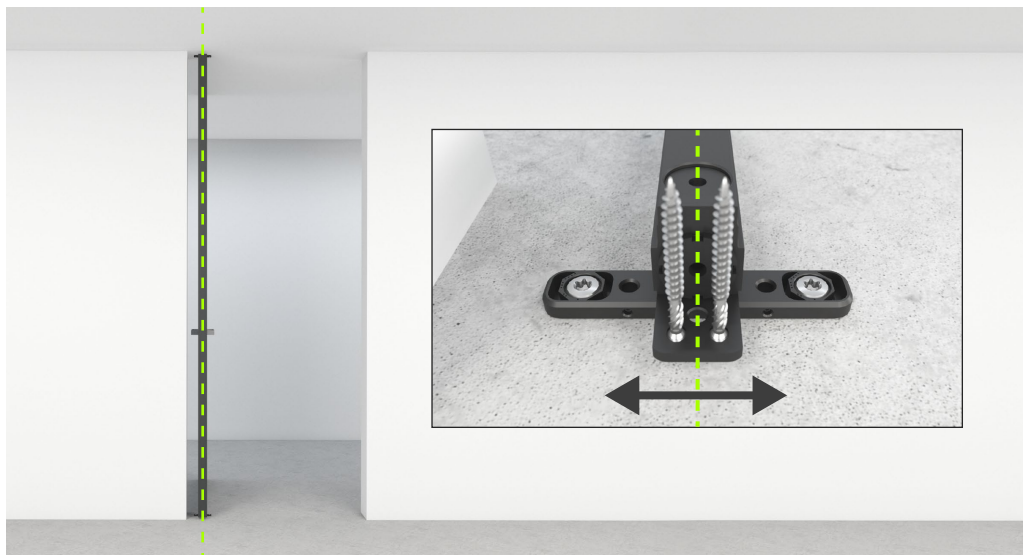

ADJUST PIVOT AXIS

To correct the pivot axis, loosen the screws and adjust the position.

This can also be used to move the door leaf slightly left or right or to adjust the joints.

After adjustment, remember to tighten screws.

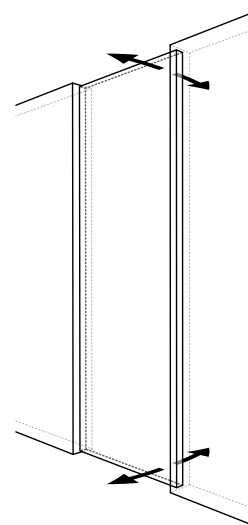
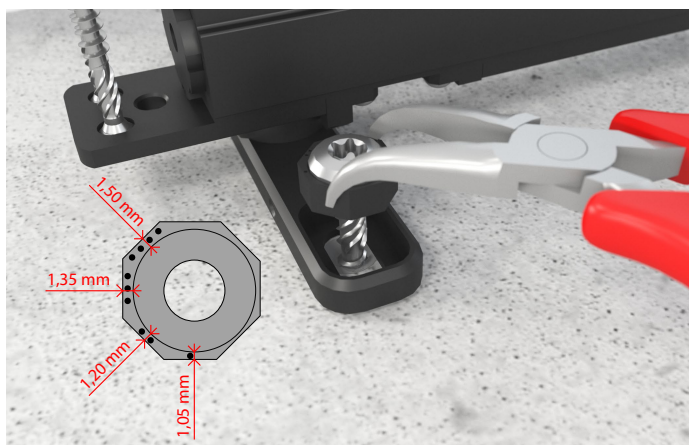

0° POSITIONING ADJUSTMENTS

Loosen the screws, and use pliers to lift the insert out of the pivot foot.

The inserts are excentric, so each position will affect the centerline angle of the door leaf.

The view below shows the effect on the centerline angle when rotating the inserts to different positions.

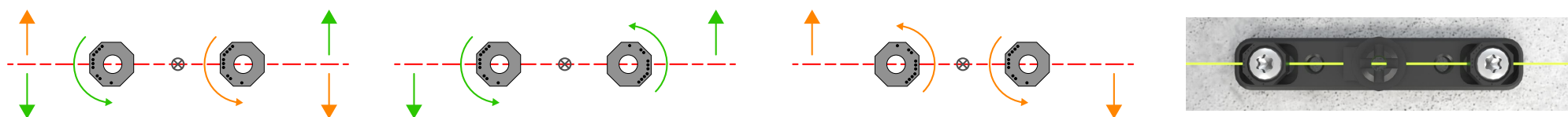

CORRECTION ANGLE DIAGRAM FOR 0° ADJUSTMENT

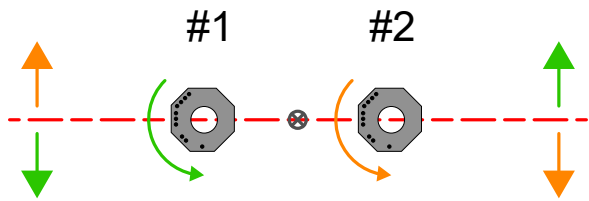

#1	#2	angle
1	1	0,00
1	2	0,13
1	3	0,25
1	4	0,38
2	1	-0,13
2	2	0,00
2	3	0,13
2	4	0,25
3	1	-0,25
3	2	-0,13
3	3	0,00
3	4	0,13
4	1	-0,38
4	2	-0,25
4	3	-0,13
4	4	0,00

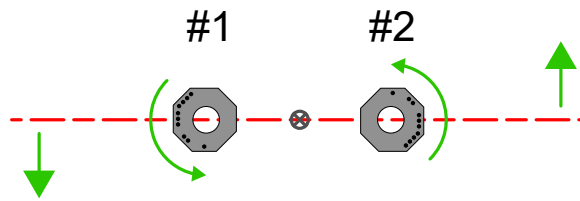

#1	#2	angle
1	1	0,00
1	2	-0,13
1	3	-0,25
1	4	-0,38
2	1	-0,13
2	2	-0,25
2	3	-0,38
2	4	-0,51
3	1	-0,25
3	2	-0,38
3	3	-0,50
3	4	-0,63
4	1	-0,38
4	2	-0,50
4	3	-0,63
4	4	-0,76

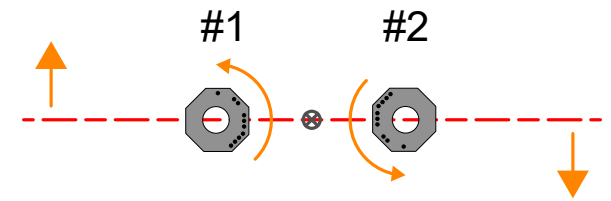



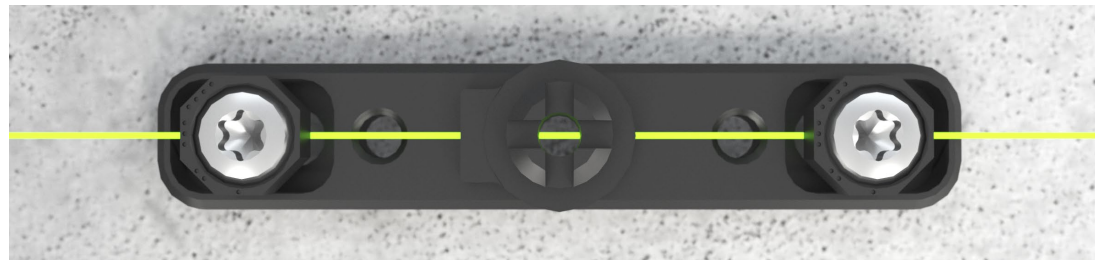

#1	#2	angle
1	1	0,00
1	2	0,13
1	3	0,25
1	4	0,38
2	1	0,13
2	2	0,25
2	3	0,38
2	4	0,51
3	1	0,25
3	2	0,38
3	3	0,51
3	4	0,63
4	1	0,38
4	2	0,50
4	3	0,63
4	4	0,76

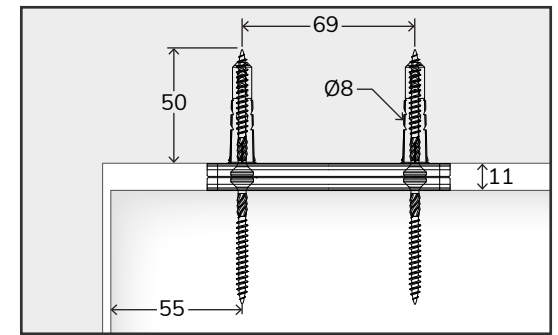
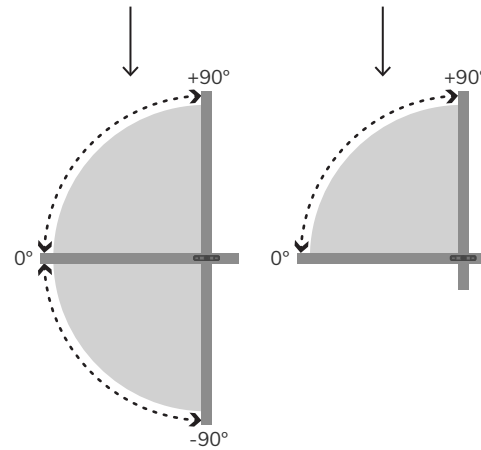
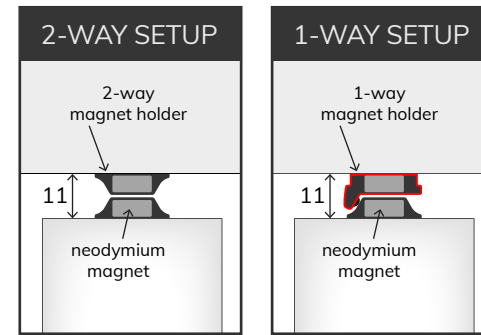
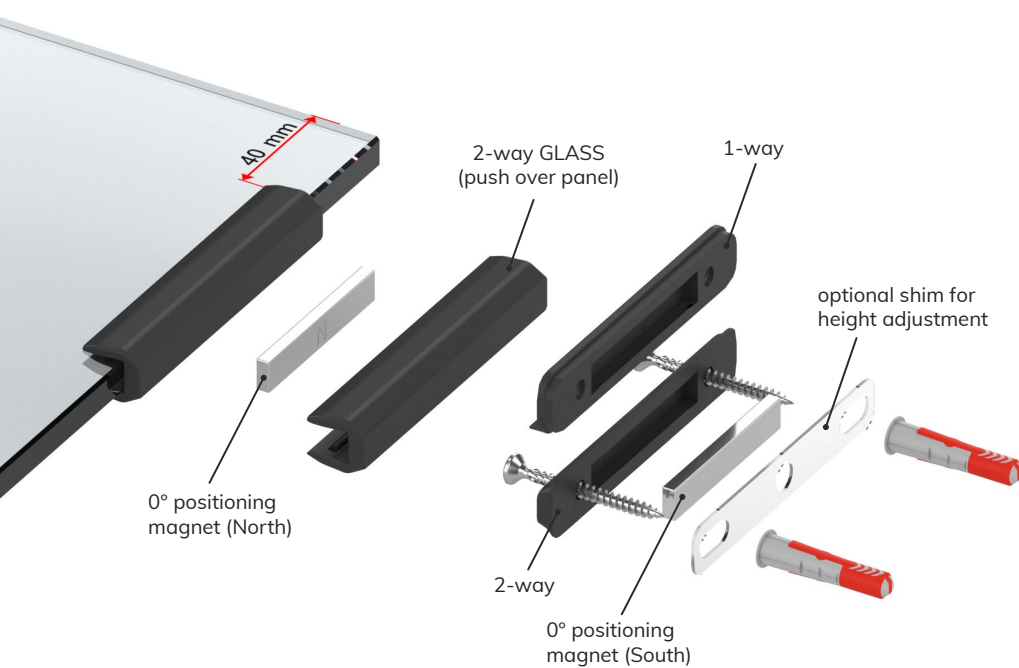
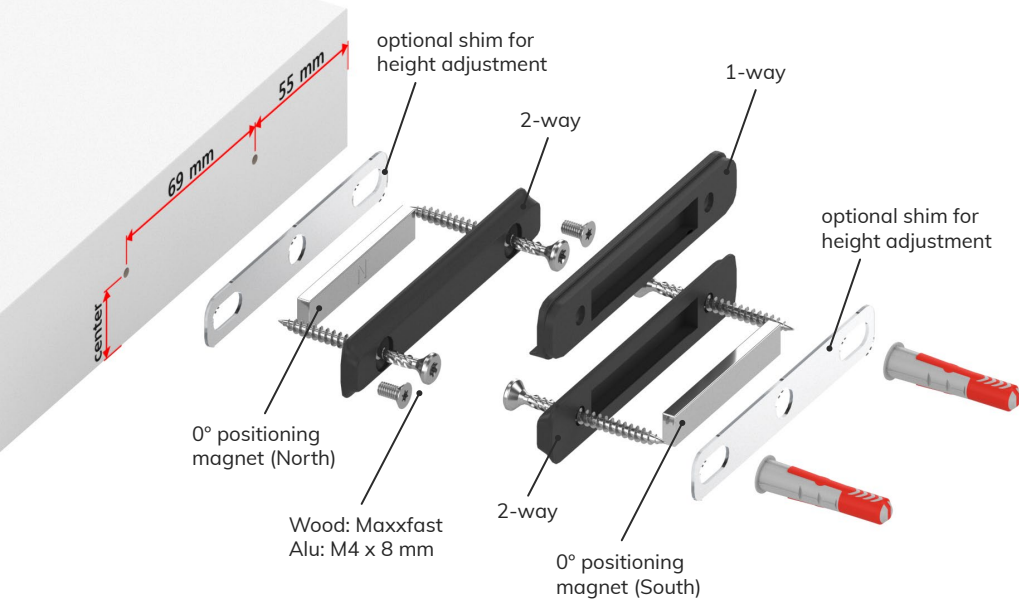

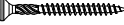
OPTIONAL 0° POSITIONING ACCESSORIES

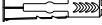

-  Maxxfast CST 4.5x50
-  M4 x 8 mm (for alu doors)
-  Fischer duopower 8x40
-  Ø8 mm

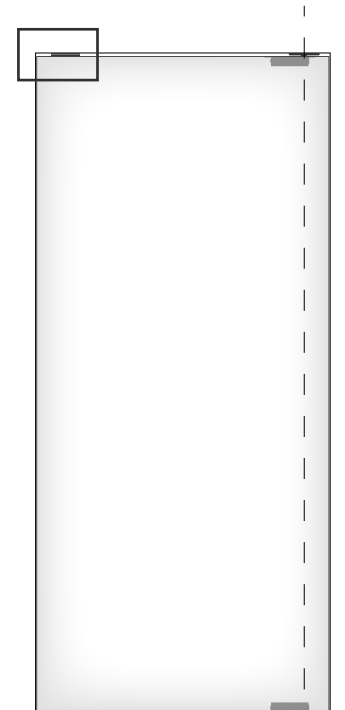
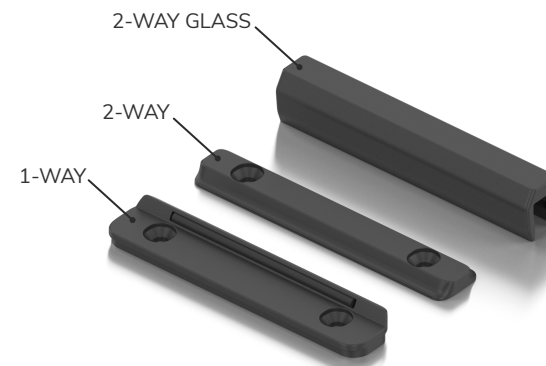

INSTALL 1/2-WAY ON CEILING

Apply a layer of masking tape onto the ceiling, and mark the location of the door 2-way on it.

Also mark the center of the doorleaf.

Position the 2-way or 1-way on your markings, and mark the drill locations.

Drill both holes and install Fischer plugs

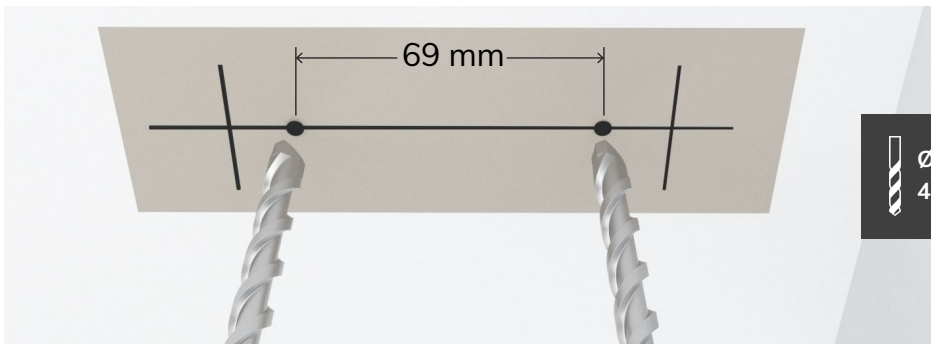
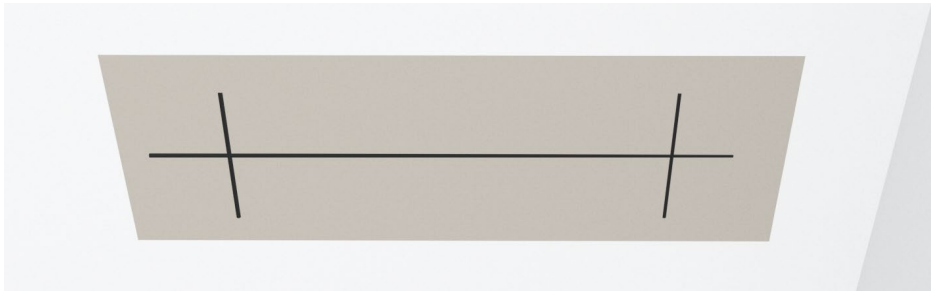

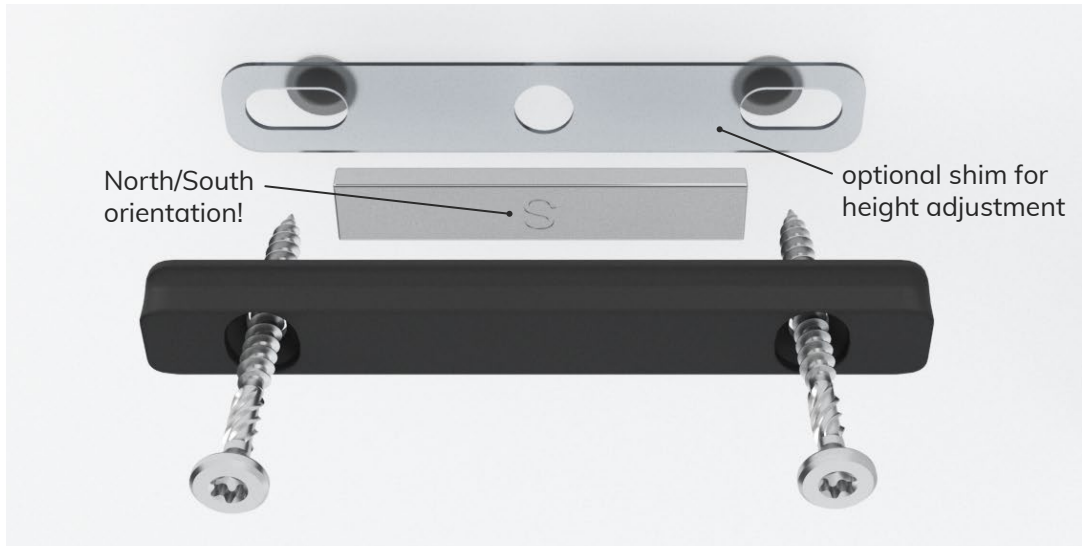

Mount the 2-way accessory using the supplied Maxxfast screws.

If height adjustment is needed, use the supplied shims.

Also note the orientation of the magnet, this should match the orientation of the door magnet!

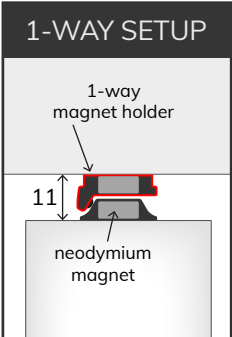
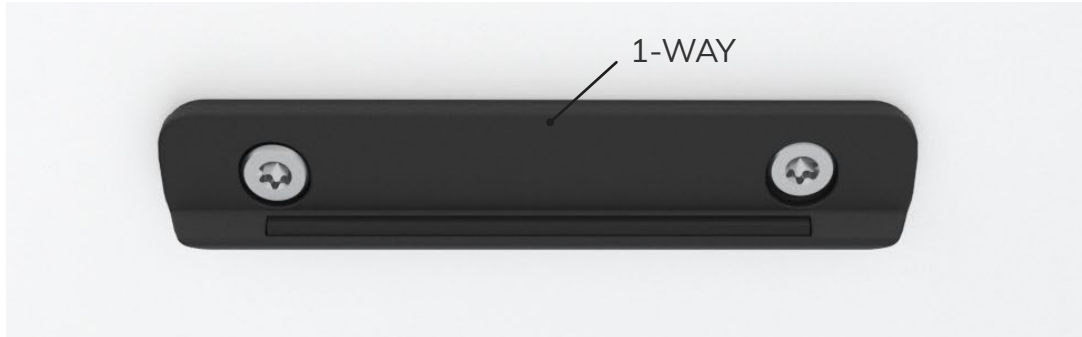
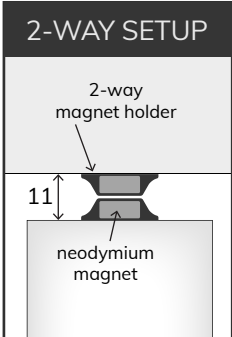
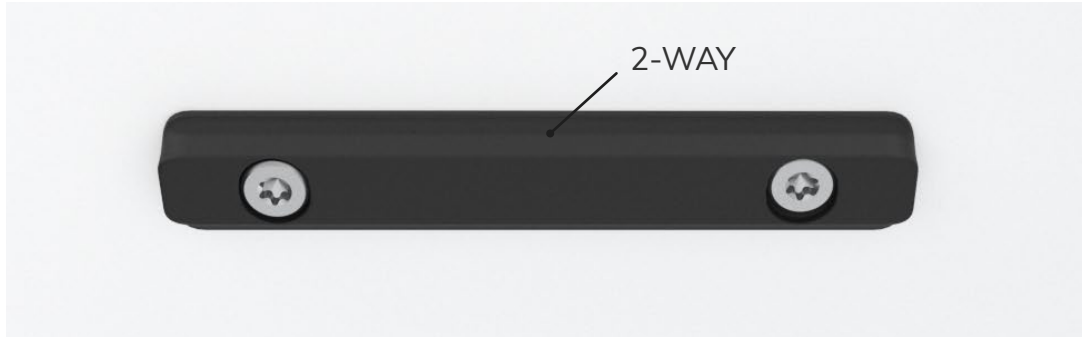

If 1-way operation is needed, use the 1-way accessory instead (also with the magnet inside).

MINIMIZE VISIBLE COMPONENTS

Slide the covers over the pivot mount to hide the screws.

