

Cabineo X

Pat. pend.

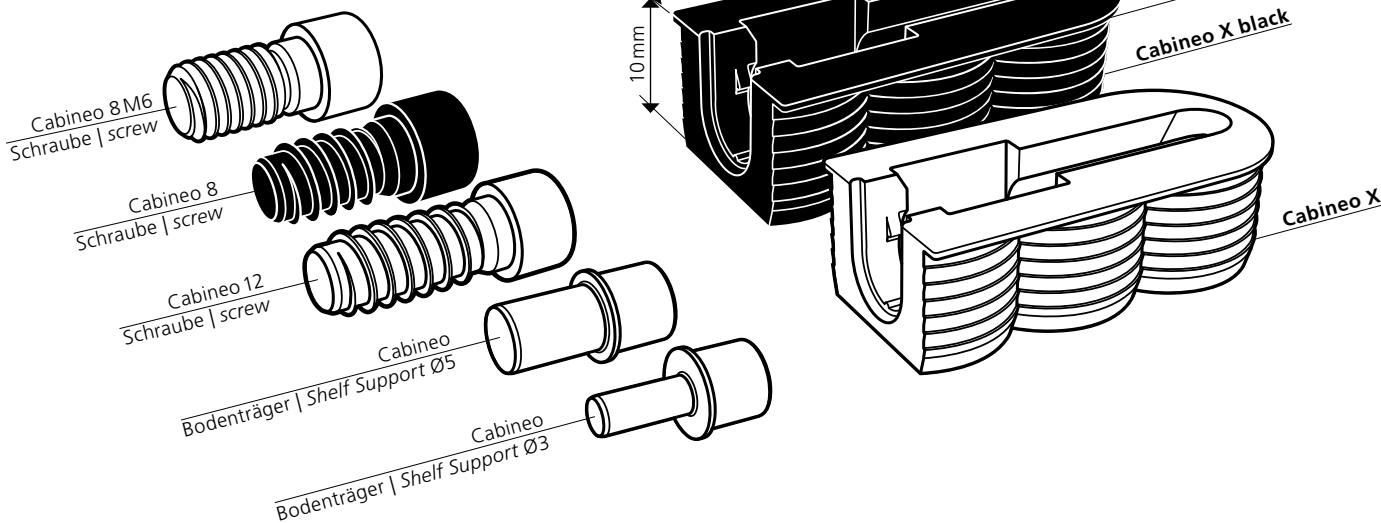

Bearbeitung mit allen CNC-Maschinen | Machining with all CNC machines

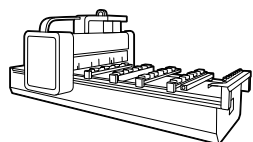

CNC-Bearbeitungszentren mit Konsolen
CNC processing centres with consoles

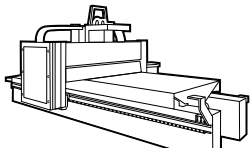

CNC-Bearbeitungszentren mit Nesting-Technologie
CNC processing centres with nesting technology

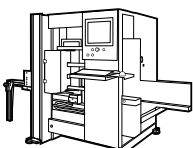

CNC-Bearbeitungszentren Vertikal
CNC processing centres Vertical

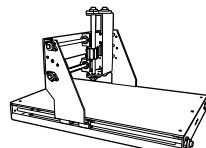

CNC Oberfräse
CNC router

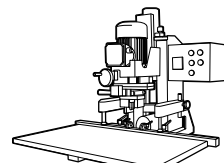

Bohr- und Beschlagsetzmaschinen
Drilling and insertion machines

Cabineo X als Korpusverbinder und Fachbodenträger | Cabineo X for cabinet connector and shelf support

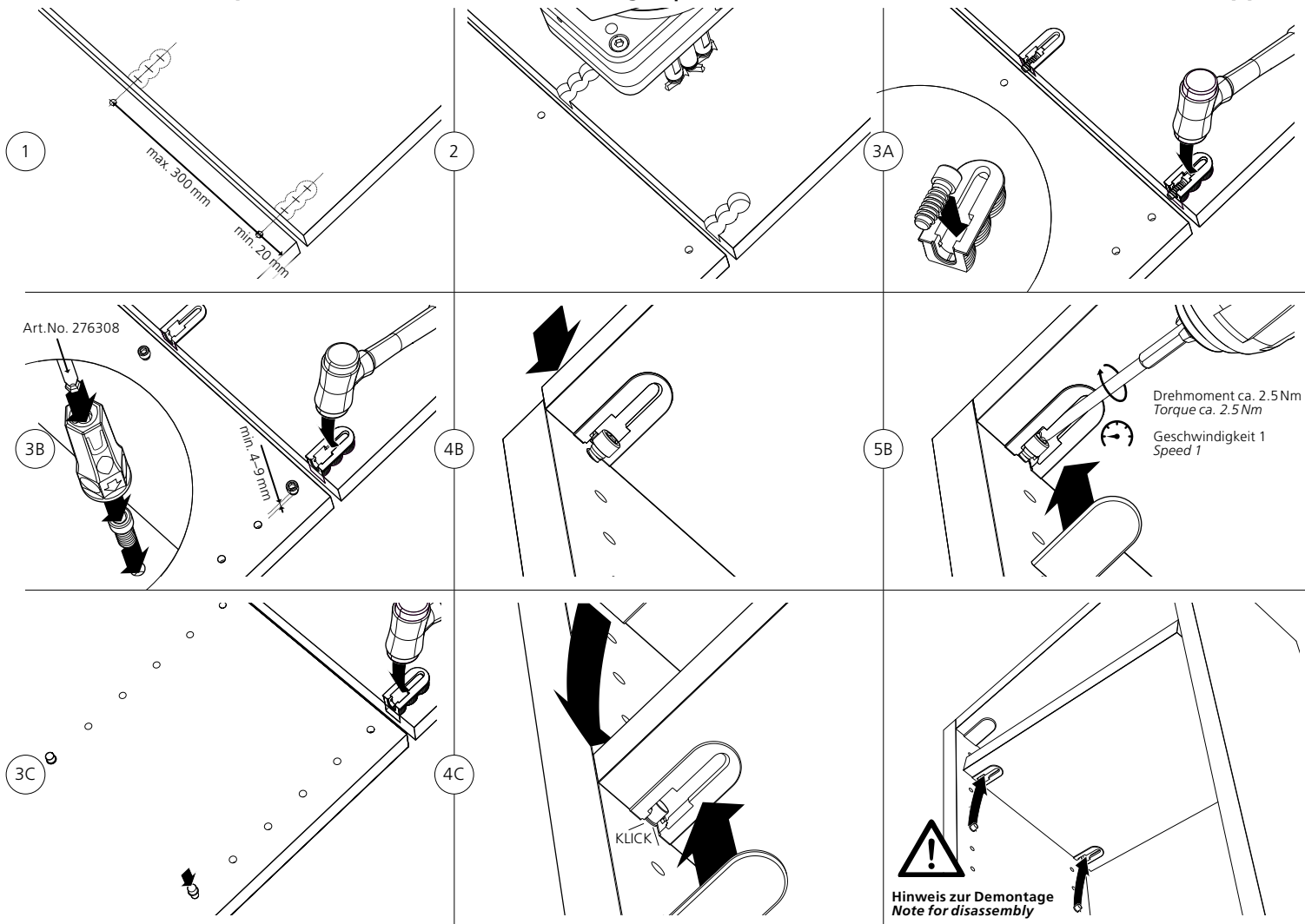

Technische Informationen Technical information

Grösse Size	33.8 x 16.5 x 10.8 mm
Fräser Cutter	≤ Ø 12 mm
Material Gehäuse	Glasfaserverstärkter Kunststoff
Material housing	Fiberglass reinforced plastic
Einbautoleranz	Längs ± 0.5 mm
Installation tolerace	Longitudinal ± 0.5 mm

Anwendungen | Applications

	Cabineo Schraube Screw 8	Cabineo Schraube Screw 12
F1 Zugfestigkeit Tensile strength 10N ~ 1 kg*	Spanplatte particle board 19 mm 480* MDF 19 mm 570* Buche 19 mm 1360*	Spanplatte particle board 19 mm 770* MDF 19 mm 830* Buche 19 mm 1980*
F2 Scherfestigkeit Shear strength 10N ~ 1 kg*	Spanplatte particle board 19 mm 530* MDF 19 mm 640* Buche 19 mm 1430*	Spanplatte particle board 19 mm 850* MDF 19 mm 1120* Buche 19 mm 1950*
F3 Scherfestigkeit Shear strength 10N ~ 1 kg*	Spanplatte particle board 19 mm 250* MDF 19 mm 370* Buche 19 mm 400*	Spanplatte particle board 19 mm 300* MDF 19 mm 410* Buche 19 mm 450*

Keine Holzdübel notwendig!
No dowel necessary!

Bearbeitung | Machining

Bund aufliegend | On the surface

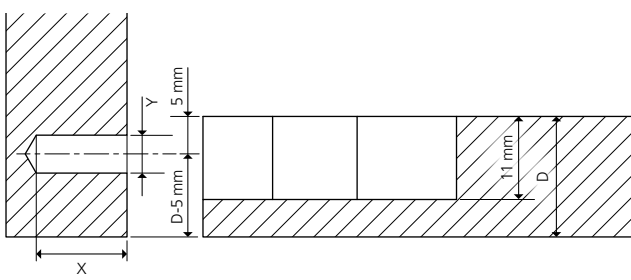
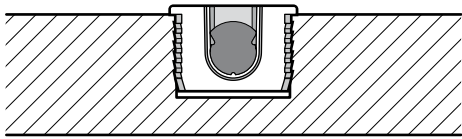

Cabineo 8: X = 8 mm / Y = 5 mm

Schwarze Schraube | black screw

Cabineo 12: X = 12 mm / Y = 5 mm

Vernickelte Schraube | nickel-plated screw

Cabineo 8 M6: X = 8 mm / Y = 5 mm

Gelb verzinkte Schraube, Metrisches ISO-Gewinde DIN 13-1 | Yellow galvanised screw, Metric ISO thread DIN 13-1

Bodenträger | Shelf Support Ø5 mm
X = 8 mm / Y = 5 mm

Bodenträger | Shelf Support Ø3 mm
X = 8 mm / Y = 3 mm

Variante | Option 1:

Bohrer Ø 15 mm | Drill Ø 15 mm

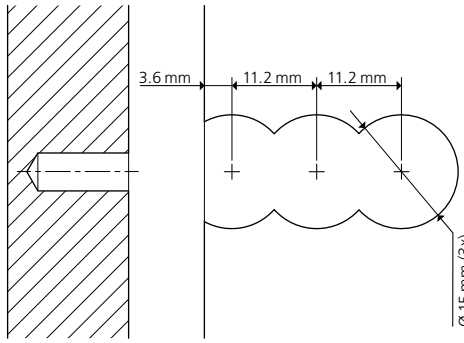
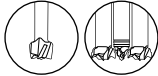

Variante | Option 2:

Fräser ≥ Ø 10 mm | Cutter ≥ Ø 10 mm

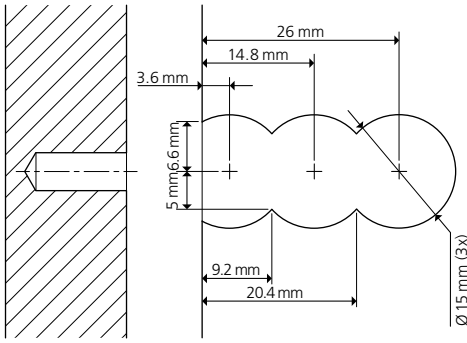

Variante | Option 3:

Fräser Ø 12 mm | Cutter Ø 12 mm

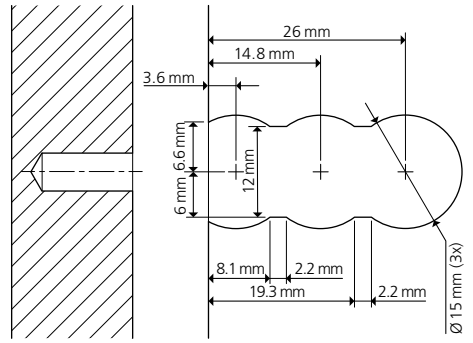

F3 Scherfestigkeit | Shear strength = -13%

Bund flächenbündig | Flush with the surface

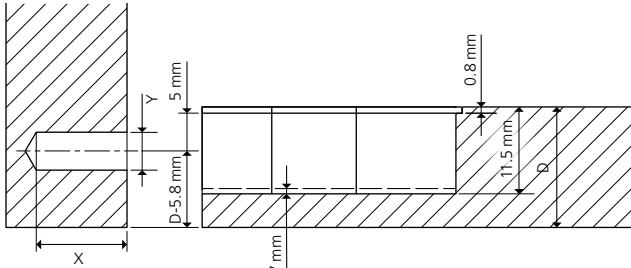
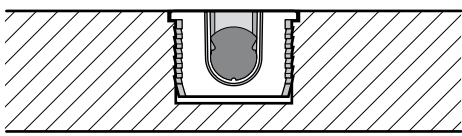

Cabineo 8: X = 8 mm / Y = 5 mm

Schwarze Schraube | black screw

Cabineo 12: X = 12 mm / Y = 5 mm

Vernickelte Schraube | nickel-plated screw

Cabineo 8 M6: X = 8 mm / Y = 5 mm

Gelb verzinkte Schraube, Metrisches ISO-Gewinde DIN 13-1 | Yellow galvanised screw, Metric ISO thread DIN 13-1

Bodenträger | Shelf Support Ø5 mm
X = 8 mm / Y = 5 mm

Bodenträger | Shelf Support Ø3 mm
X = 8 mm / Y = 3 mm

Variante | Option 1:

Bohrer Ø 15 mm | Drill Ø 15 mm

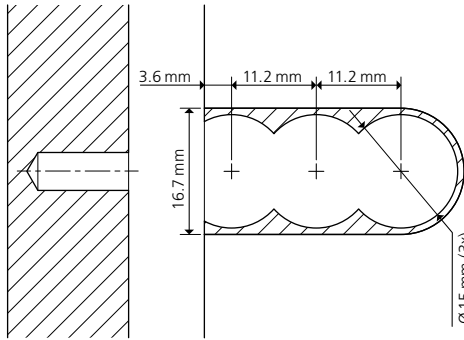
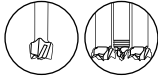

Variante | Option 2:

Fräser ≥ Ø 10 mm | Cutter ≥ Ø 10 mm

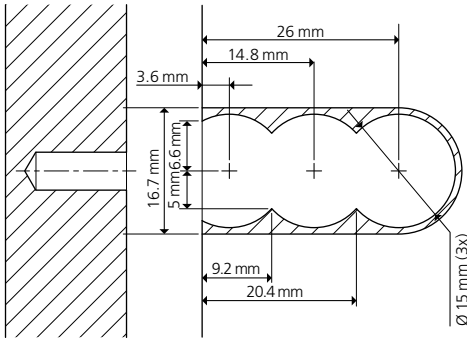

Variante | Option 3:

Fräser Ø 12 mm | Cutter Ø 12 mm

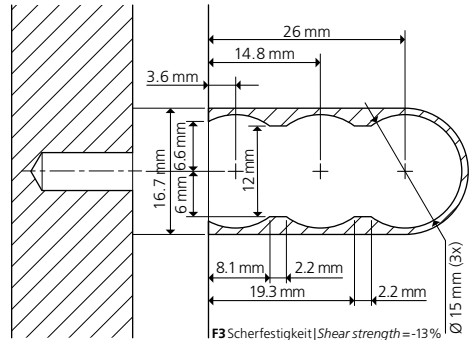

F3 Scherfestigkeit | Shear strength = -13%

Abdeckkappen flächenbündig | Flush cover cap

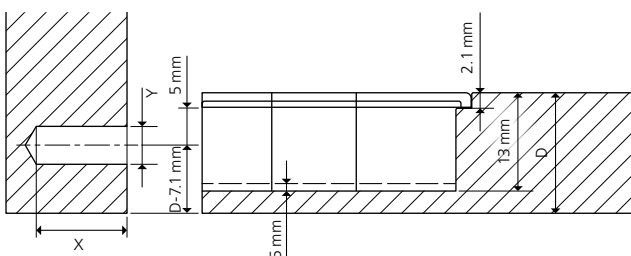
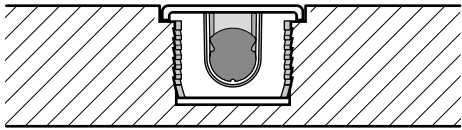

Cabineo 8: X = 8 mm / Y = 5 mm

Schwarze Schraube | black screw

Cabineo 12: X = 12 mm / Y = 5 mm

Vernickelte Schraube | nickel-plated screw

Cabineo 8 M6: X = 8 mm / Y = 5 mm

Gelb verzinkte Schraube, Metrisches ISO-Gewinde DIN 13-1 | Yellow galvanised screw, Metric ISO thread DIN 13-1

Bodenträger | Shelf Support Ø5 mm
X = 8 mm / Y = 5 mm

Bodenträger | Shelf Support Ø3 mm
X = 8 mm / Y = 3 mm

Variante | Option 1:

Bohrer Ø 15 mm | Drill Ø 15 mm

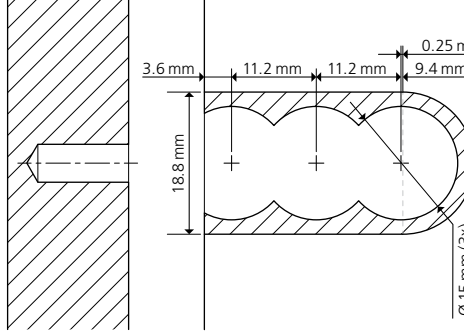

Variante | Option 2:

Fräser ≥ Ø 10 mm | Cutter ≥ Ø 10 mm

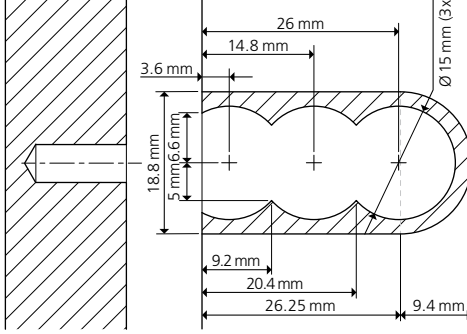

Variante | Option 3:

Fräser Ø 12 mm | Cutter Ø 12 mm

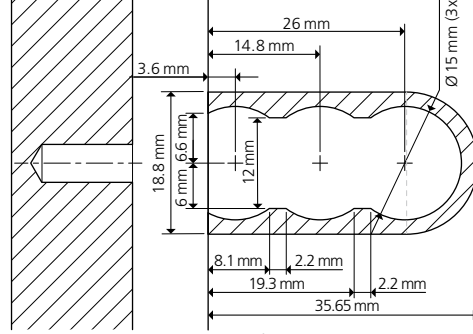

F3 Scherfestigkeit | Shear strength = -13%

HPL Bund aufliegend | HPL on the surface

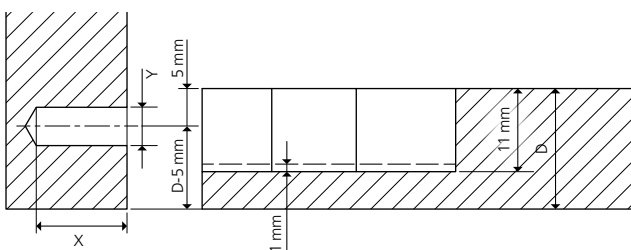
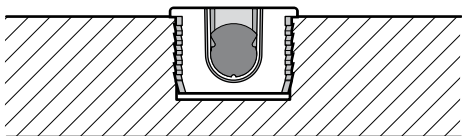

Cabineo 8 M6: X = 8 mm

Gelb verzinkte Schraube, Metrisches ISO-Gewinde DIN 13-1 | Yellow galvanised screw, Metric ISO thread DIN 13-1

Variante | Option 1:

Bohrer Ø 15 mm | Drill Ø 15 mm

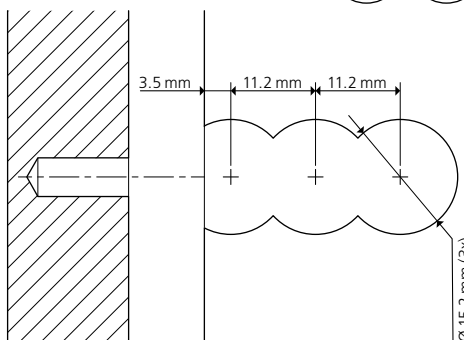
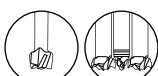

Variante | Option 2:

Fräser ≥ Ø 10 mm | Cutter ≥ Ø 10 mm

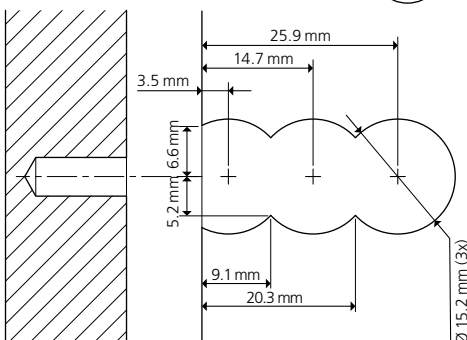

Variante | Option 3:

Fräser Ø 12 mm | Cutter Ø 12 mm

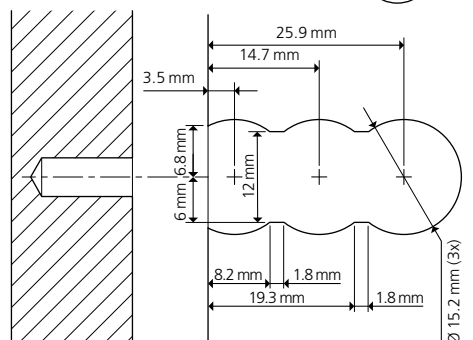

F3 Scherfestigkeit | Shear strength = -13%